

Aitkin County
Wastewater Treatment and Dispersal Permit

Permit Number: _____ Date: _____

Facility Information

Permittee name: Patrick & Jane Jacobwith Phone number: 612-386-6911
 Mailing address: 49131 373rd Place
 City: Palisade State: MN Zip code: 56469
 Property ID number (GPS location): 35-0-027512

Aitkin County authorizes the Permittee to operate a wastewater treatment and dispersal system at the address named above in accordance with the requirements of this operating permit. The attached Management Plan is hereby incorporated as part of the requirements of this operating permit.

Issuance date: _____ Expiration date: _____
 System type: Mound with soil correction/digout Treatment level: C
 System design flow: 300 GPD Residential/Commercial: Residential

System Components: Existing 1250 Combo (1) New Infiltrator IM540 Septic Tank, (1) New Infiltrator IM1060 time dose pump tank, 10' x 25' rockbed, 1' sand lift mound.

Monitoring Requirements

Parameter	Effluent limits	Frequency	Location
Peak flow (gpd)	300	Annually 1 x yr	Dosing Tank
Average flow (gpd)	210	Annually 1 x yr	Dosing Tank
CBOD ₅ (mg/L)	na		
TSS (mg/L)	na		
Fog (mg/l)	na		
Ponding/Surfacing in soil treatment	none		

Maintenance Requirements

Maintenance requirements shall be performed as specified in the Management Plan as prepared by the system's Advanced Designer.

System component	Maintenance	Frequency
Septic tank/Trash tank	Check monthly, pump as needed	Annually 1 x yr
Pump tank and controls	Check monthly, pump/replace as needed	Annually 1 x yr
Effluent screen	Check monthly, clean as needed	Annually 1 x yr
Advanced treatment product	Per Service Plan	Annually 2 x y1
Soil treatment and dispersal	Clean/jet laterals	As needed – 1 st cleaning not expected for 3-5 years, maybe longer
Ponding/Surfacing in soil treatment	Check yearly, repair as needed.	Annually 1 x yr

Monitoring Protocol

Any sampling and laboratory testing procedures shall be performed in accordance with the proprietary treatment product's protocol, Standard Methods, and at a Minnesota Department of Health approved laboratory. Results shall be submitted to the permitting authorities at: Aitkin County Land Services.

Contingency Plan

In the event the wastewater treatment system does not meet required performance requirements as contained in this operating permit, the owner shall notify the local unit of government within 30 days of non-compliance. The owner is responsible to obtain the services of a Minnesota Pollution Control Agency (MPCA)-licensed Service Provider or other qualified practitioner to complete the required corrective measures.

Authorization

This permit is effective on the issuance date identified above. This permit and the authorization to treat and disperse wastewater shall expire one year from date of issue.

This system will be Compliant as long as the conditions of the Operating Permit are met. This permit will need to be renewed 30 days before expiration date.

Any additional tanks or equipment that need to be added to meet standards required by this permit due to expansion, failure of equipment, or increased flow shall not require additional permits provided that this system is current with the standards outlined in this operating permit.

The Permittee is not authorized to discharge after the above date of expiration.

The Permittee shall submit monitoring information and forms as required by Aitkin County Land Services yearly no later than sixty (60) days after service date. This permit is not transferable.

The owner is required to obtain the services of a Minnesota Pollution Control Agency (MPCA) licensed 1) Service Provider to provide ongoing system operation, maintenance, and monitoring and 2) Maintainer to pump the system's sewage tanks and components. The owner is responsible to provide the name of the Service Provider business prior to the issuance of this operating permit.

I hereby certify with my signature as the Permittee that I understand the provisions of the wastewater treatment and dispersal system operating permit including maintenance and monitoring requirements. I agree to indemnify and hold either Aitkin County Land Services harmless from all loss, damages, costs and charges that may be incurred by the use of this system. If I fail to comply with the provisions of this operation permit, I understand that penalties may be issued. If I sell this property during the life of the permit, I will inform the new owner(s) of the permit requirements and the need to renew the operating permit.

The Operating Permit is hereby granted to:

Permittee
(please print): _____

Permitting Authority
(please print): _____

Title: _____ Date: _____

Title _____ Date: _____

Signature: _____

Signature: _____

Instructions for Completing an Operating Permit

The following instructions provide an explanation for local units of government to complete the operating permit template. This is intended to provide guidance to local units of governments (LGU) in developing operating permits for Type IV and Type V systems, including both residential and commercial systems. The template could be modified for holding tanks. Since the Management Plan is considered part of the operating permit, it needs to be attached to the operating permit. A signed contract, between the owner and Service Provider, should be attached to the operating permit to help ensure the owner has made the necessary arrangements to have the system maintained and monitored.

LGU Name, Department and Address – fill in the name, department and address of local unit of government at the top of the operating permit.

Wastewater Treatment and Dispersal Operating Permit No. – assign an operating permit number to be able to track the system over the years.

Permittee Name, Telephone Number, and Address – fill in the name, address and phone number of the owner.

Property Id. Number (GPS Location) – these are simply identifiers used by local units of government in the event the property address changes over time.

Name of Local Unit of Government – fill in the name of the local unit of government. This authorizes the Permittee to operate the wastewater treatment system at the address named above, according to the operating permit, attached Management Plan and contract with the Service Provider.

Issuance Date – fill in the date the operating permit is issued. The operating permit should not be issued until all required information is submitted.

Expiration Date – fill in the date when this operating permit expires. The first time an operating permit is issued to an owner, it should be issued for one (1) year. This helps ensure the owner actually does the required maintenance and monitoring during the first year. If the owner complies, the operating permit can then be issued for a longer period of time as determined by the local unit of government (typically 3 to 5 years). However, if the owner does not comply the first year, the second operating permit could, again, be issued for a period of one (1) year.

System Type – fill in as Type IV or Type V system. Holding tanks also require operating permits (Type II system).

Treatment Level – specify Treatment Level A, B, C, TN or TP. Treatment Level A = Carbonaceous Biochemical Oxygen Demand, five day (CBOD₅) 15 milligrams per liter (mg/L), Total Suspended Solids (TSS) 15 mg/L, Fecal Coliform Bacteria 1000 per 100 milliliter (mL); Treatment Level B = CBOD₅ 25 mg/L, TSS 30 mg/L, Fecal Coliform Bacteria 10,000 per 100 mL; Treatment Level C = CBOD₅ 125 mg/L, TSS 80 mg/L, Oil and Grease 20 mg/L; TN = 20 mg/L, or TP = 2 mg/L.

System Design Flow – fill in the design flow specified on the construction permit for the system, along with the projected average daily flow for the system. Average daily flow is generally 60 to 70 percent of design flow.

Residential/Commercial – specify if the system is residential or commercial. You may specify additional information, such as classification of dwelling, number of bedrooms; or type of commercial establishment.

System Components – provide a brief description of the system components. An example would be the following: 600 gallon trash tank, 600 gallon ECOPOD treatment device, 1 Salcor Ultra Violet (UV) light disinfection unit, 500-gallon pump tank, pump, floats and controls, and 250-foot shallow trenches using pressure distribution.

Monitoring Requirements (Table)

The monitoring requirements specified in an operating permit are unique to the site and soil conditions of the property (its environmental sensitivity) and system complexity. The monitoring requirements include specific parameters to be monitored, target limits and the frequency and location of monitoring. The monitored parameters, at a minimum, would include: 1) wastewater flow - the most basic parameter to know in understanding system performance, 2) ponding in the soil treatment system and 3) surfacing of the soil treatment system. Monitoring for CBOD₅, TSS, fecal coliform bacteria and nitrogen are unique to the site, its receiving environment and complexity of the wastewater system. Field tests for temperature, pH and dissolved oxygen can be performed by the Service Provider to serve as general indicators of system performance.

1. **Flow** – flow to each system needs to be determined as specified in the Management Plan or as determined by the local unit of government. Flow can be determined several ways, using water meters, event counters, and running time clocks. Telemetry can also be used and has the advantage that flow can be determined continually.

The determination for the frequency of flow measurement is done on a case-by-case basis. At first, daily flow monitoring may be needed to determine average flow and peak flows to a system. After a period of time, weekly or monthly flow determination may be acceptable. Flow determinations once a year generally provide limited information.

2. **CBOD₅** – monitoring for CBOD₅ is not typically required for the majority of wastewater systems used for single-family homes generating typical domestic strength effluent. However, monitoring for CBOD₅ may be needed periodically. For example, there may be a need to audit systems as part of the product registration process in Minnesota or if the Service Provider is trying to troubleshoot a system. For commercial systems, monitoring for CBOD₅ is generally necessary to determine CBOD₅ removal efficiencies of proprietary treatment devices and/or organic loading rates to the soil's infiltrative surface.
3. **TSS** – monitoring for TSS is not typically required for most residential wastewater systems that generate typical domestic strength effluent. However, turbidity measurements may be taken in the field by Service Providers. Monitoring for TSS may be needed periodically as part of an audit process for the registration of proprietary treatment products in Minnesota. For commercial systems, monitoring for TSS may be necessary.
4. **Fecal Coliform Bacteria** – monitoring for fecal coliform bacteria should generally be required for systems listed as Treatment Level A and Treatment Level B systems where reduced vertical soil separation is used.
5. **Total Nitrogen and Total Phosphorus** – monitoring for Total Nitrogen (TN) may be needed in areas identified as nitrogen sensitive environments. Monitoring for Total Phosphorus (TP) may be required in phosphorus sensitive lake environments.
6. **Field Tests** – these are tests performed by the Service Provider to help 'monitor' system performance and identify problems (troubleshooting a system). Although field tests are not a strict monitoring requirement, they are appropriate to list in the operating permit if specified in the Management Plan or in the product's Operation and Maintenance Manual. The local unit of government will determine if the permittee is required to report field test results as part of the operating permit.
7. **Ponding/Surfacing in Soil Treatment** – all systems should be monitored periodically as specified in the Management Plan to determine extent and frequency of ponding in soil treatment systems. A check for surfacing is needed.

Maintenance Requirements (Table)

This table lists some of the basic maintenance requirements for each major component of the wastewater system. Since you can't possibly list all the maintenance requirements in this table, it is best to reference the Management Plan. You could reference the proprietary product's Operation and Maintenance Manual.

1. **System Component** – list each system component, including the septic tank, trash tank, effluent screen, pump tank and controls, proprietary treatment product, disinfection device, and soil treatment and dispersal system.
2. **Maintenance** – briefly identify the maintenance requirements of each major system component. For additional information, you could also reference the proprietary product documents listed on the MPCA Web site at <http://www.pca.state.mn.us/programs/ists/productregistration.html>.
3. **Frequency** – briefly identify the frequency of maintenance as per the systems Management Plan and Operation and Maintenance Manual.

Monitoring Protocol – this section of the operating permit states that testing needs to be performed in accordance with approved methods and the results submitted to the local unit of government.

Contingency Plan – briefly describes requirements if the system does not function as intended. The owner must notify the local unit of government when non-compliance occurs. The Management Plan may identify some of the corrective actions required or you will need to consult your Service Provider. The owner is responsible to obtain the services of a MPCA-licensed Service Provider or other qualified practitioner to complete the required corrective measures. More detail could be added here by the local unit of government.

Authorization – fill in the length of time of the operating permit; this is typically one to five years. Fill in the name of the local unit of government in the second blank space. Next, fill in the name of the MPCA licensed Service Provider identified by the owner in contract; this is needed to help ensure the owner has made the necessary arrangements to have the system maintained and monitored.

The Operating Permits Hereby Granted to – print the name of the owner who signed the operating permit.

Signature of Permittee (and date of signature) – the owner signs and dates the operating permit.

By Order of – signature of the permitting authority, title, and date.

SEPTIC CHECK

EXPERT SERVICE. LASTING VALUE. CLEAN WATER

INDIVIDUAL SEWAGE SYSTEM DESIGN SUMMARY

Property Owner: Patrick & Jane Jacobwith Phone: 612-386-6911

Address: 49131 373rd Place PID: 35-0-027512

City: Palisade Zip: 56469 County: Aitkin

DESIGN USAGE

Single Family Home x Other _____

Number of Potential Bedrooms 4 Designed as 2

Garbage Disposal No

Sewage Lift Pump No

SITE CHARACTERISTICS

Soil type Loamy Sand

Hydraulic Loading 1.20 gpd/ft2

Depth to restrictive layer 26"

PUMP INFORMATION

Pump GPM & TDH 18 GPM & 15.7 TDH

Cycles per day 4 Doses

Gallons per cycle 50 gallons

Perforation size & spacing 1/4" perfs every 36"

Number, spacing, & diameter of laterals 3 - 1 1/2" laterals every 36"

Forcemain Size 2"

CAPACITIES

Daily Water Use _____ Est 300 gpd Calc _____
Existing - 1250 Combo

Septic Tank Capacity New - Infiltrator IM-540

Pump Tank Capacity New - Infiltrator IM-1060

MOUND SYSTEM

Dimension of Rock Base 10' x 25'

Depth of Rock Below Pipe 9"

Dimensions of Mound 34.4' x 49.4'

% Slope of Soil Under Mound 0% after scratch

Upslope Dike Width 12.2'

Downslope Dike Width 12.2'

Sideslope Dike Width 12.2'

TRENCH SYSTEM

Type of trench _____

Maximum Depth of trench _____

Square Feet of bed Required _____

Square Feet of bed Proposed _____

Lineal Feet of bed Proposed _____

APPROVAL

By  Date 11/11/20

Melissa Besser License #2624

See additional information sheet if checked



Septic System Design Additional Information



Property

Owner: Patrick & Jane Jacobwith – 49131 373rd Place – Palisade, MN 56469

Existing System Summary:

This is a Class 1 home with 4 bedrooms, it does not have a garbage disposal or sewage ejector. The existing septic system did not pass a compliance inspection on 07/31/20. The drainfield did not meet soil separation requirements; however, the existing 1250-gallon combo tank passed and will be reused in this design.

Soil Observation:

The soil profile identified on the property consisted of Loamy Sand. For this design we will be using the soil loading rate for Loamy Sand at 1.20 gpd/ft². Redox features were present in all the observations with 26" being the most restrictive.

Type III System:

This design employs time dosing to reduce the size of the drainfield so it fits on the lot. The proposed system will go from a 4 bedroom at 600 GPD to a 2 bedroom system at 300 GPD. The 10' x 25' rockbed scratch will need to be a dug to an elevation of 99.10 which is equal to the NW rockbed corner. This will make the area flat as well as change the slope to 0% from 5%. These alterations make this a Type III system that will require an operating permit with Aitkin County until they are satisfied with the system's performance.

Aitkin County Variance Required:

To keep the mound footprint inside property lines a variance will need to be granted by Aitkin County. The request is to allow for a reduction in the setback from the dwelling to the drainfield. A setback reduction from 20 feet to 14 feet is necessary on this lot.

Proposed Update Summary:

Access is limited so polypropylene tanks will need to be used. Sewage will flow by gravity from the home into the existing 1,250 gallon 2-compartment septic tank, from there effluent will flow by gravity to a 500-gallon single compartment septic tank. Effluent will then flow by gravity to a 1,000-gallon pump tank. The pump installed must deliver at least 18.0 GPM and 15.7 TDH. All manholes will need to be installed to grade for ease of servicing. Effluent will then be time dosed to a 10' by 25' rockbed mound with 1' of washed sand and 1' of washed 1 ½" rock. It will have laterals, cleanouts and inspection pipes to grade.

System detail:

- Infiltrator IM-540 for the 2nd septic tank
- Infiltrator IM-1060 for the 1000-gallon pump tank
- (3) 24" insulated manhole covers to grade.
- Ultra-rib riser attached with ADH 100 - or two-part epoxy
- Insulate top of tank if buried less than 2'
- Goulds PE 31 effluent pump
- IFS Single Phase Simplex Time Dose Panel
- 4" SCH 40 for collection lines
- 2" SCH 40 for the forcemain
- 10' x 25' Rockbed; Total Mound Footprint 34.4' x 49.4'
- (3) - 23' laterals using 1 ½" SCH 40 pipe
- Elevations are referenced to the Benchmark which is the top of the outlet manhole cover on the existing 1,250-gallon combo tank

Water supply / wells:

The existing shallow point well is to be capped. A new deep well is to be dug making the proposed drainfield and tank locations over 50' away.

Homeowner Responsibility:

Homeowner to verify all property lines.

Each tank is to be pumped through the maintenance cover when serviced. Do not pump through inspection pipes.

Homeowner is responsible for all costs involved in servicing, monitoring, and mitigating the system.

Keep all vehicles off septic area. Rutting and/or compacting the soil will change the percolation rates and may lead to system failure.

Installer Responsibility:

It is the installer's responsibility to make sure the septic system is seeded and mulched prior to final completion.

Keep all vehicles and construction equipment off septic area. Rutting and/or compacting the soil will change the percolation rates and may lead to system failure.

Installer to verify all elevations, dimensions, and ensure proper fall to pipes. Pitch pump chamber outlet to ensure complete drainback to pump chamber.

Establish turf to prevent erosion and freezing.

All construction to be performed in accordance with MN Rule 7080 and the Aitkin County septic ordinance.

Maintenance Requirements

See attached operating permit or management plan for details



SCALE - 1" = 20'

PREPARED FOR:
Patrick & Jane Jacobwith

PROPERTY LOCATION:
49131 373rd Place
Palisade, MN 56469

LEGAL DESCRIPTION:
Aitkin County, Minnesota
Pkg 35-0-027912

SEPTIC CHECK:
6074 KEVSTONE RD MILACA, MN 56353
(320)-983-2447 (FAX) (320)-983-2151

I hereby certify that this site plan was prepared by me or under my direct supervision.
Melissa Beaser M. P. C. A. License # 2624 11/11/20

PAGE TITLE:
SEPTIC DESIGN

SHEET NUMBER:
1 OF 1

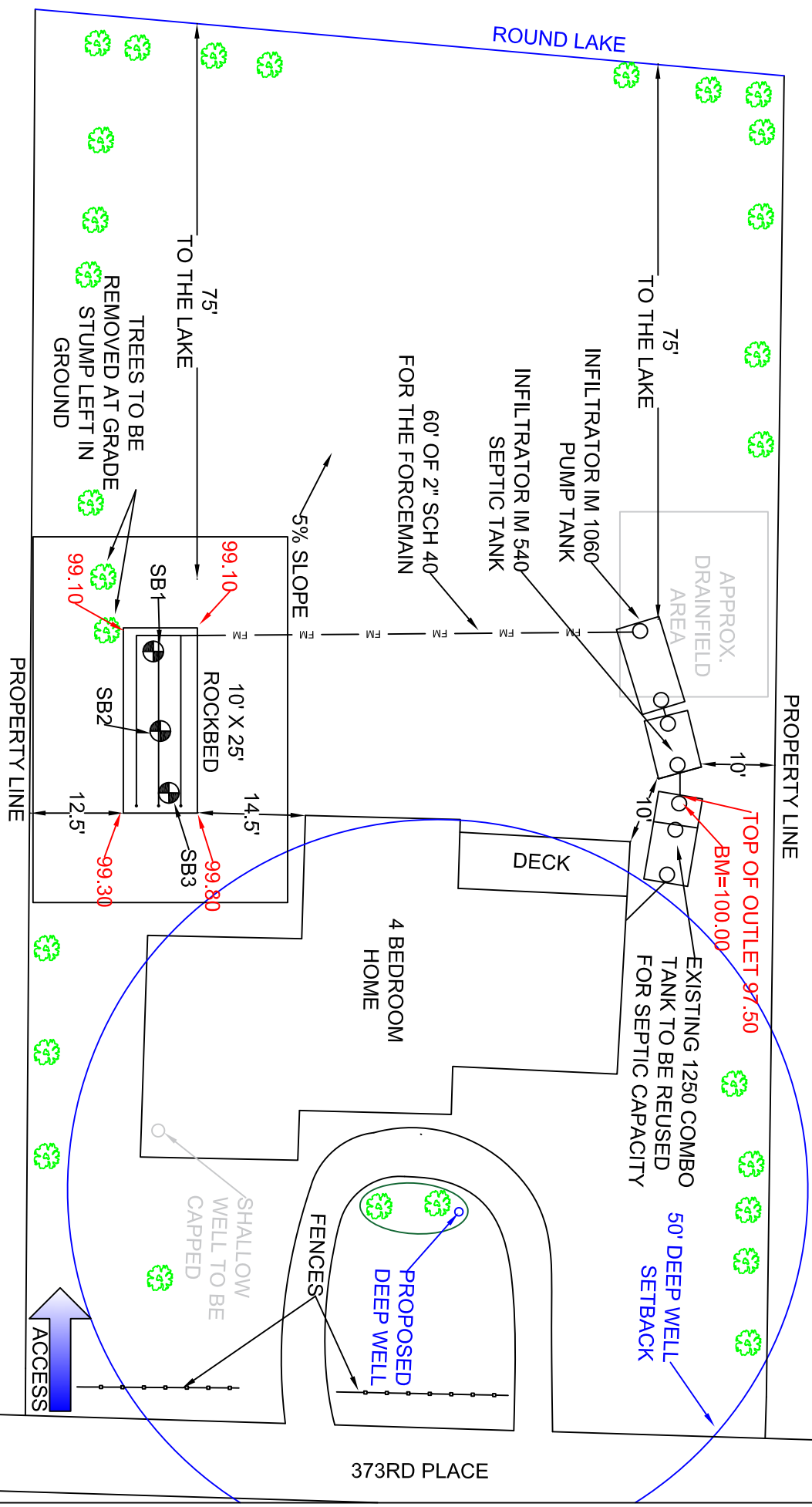

SEPTIC CHECK

EXPERT SERVICE. LASTING VALUE. CLEAN WATER

Patrick & Jane Jacobwith – 49131 373rd Place – Palisade, MN 56469



Front of home



Back of home
And new deep well location



Existing 1250 combo to be reused for septic capacity
Arrow points to existing non-compliant drainfield



Equipment access located at SE corner of the lot;
Fence to be removed by homeowner

SEPTIC CHECK

EXPERT SERVICE. LASTING VALUE. CLEAN WATER



Staked 10' x 25' rockbed facing East. Marked trees to be cut at grade with stumps in place by homeowner prior to installation



Staked rockbed facing west

SEPTIC CHECK

EXPERT SERVICE. LASTING VALUE. CLEAN WATER



NE rockbed corner is 14.5' from the home. A variance request to reduce the setback to the dwelling will be needed.

1. PROJECT INFORMATION		v 04.01.2020
Property Owner/Client:	<input type="text" value="Patrick & Jane Jacobwith"/>	Project ID: <input type="text"/>
Site Address:	<input type="text" value="49131 373rd Place Palisade, MN 56469"/>	Date: <input type="text" value="11/11/20"/>
Email Address:	<input type="text" value="patrick.jacobwith@sunsetsecure.com"/>	Phone: <input type="text" value="612-386-6911"/>
2. DESIGN FLOW & WASTE STRENGTH <i>Attach data / estimate basis for Other Establishments</i>		
<p style="color: red; font-weight: bold;">Actual design flow is 600 GPD. Designing @300 GPD with time dosing in order to get a drainfield to fit. A variance for setback is needed.</p>		
Design Flow:	<input type="text" value="300"/> GPD	Anticipated Waste Type: <input type="text" value="Residential"/>
BOD:	<input type="text"/> mg/L	TSS: <input type="text"/> mg/L
Oil & Grease:	<input type="text"/> mg/L	
Treatment Level:	<input type="text" value="C"/>	<i>Select Treatment Level C for residential septic tank effluent</i>
3. HOLDING TANK SIZING		
Minimum Capacity: Residential =400 gal/bedroom, Other Establishment = Design Flow x 5.0, Minimum size 1000 gallons		
Code Minimum Holding Tank Capacity:	<input type="text"/> Gallons	in <input type="text"/> Tanks or Compartments
Recommended Holding Tank Capacity:	<input type="text"/> Gallons	in <input type="text"/> Tanks or Compartments
Type of High Level Alarm:	<input type="text"/> (Set @ 75% tank capacity)	
Comments:	<input type="text"/>	
4. SEPTIC TANK SIZING		
A. Residential dwellings:		
Number of Bedrooms (Residential):	<input type="text" value="4"/>	
Code Minimum Septic Tank Capacity:	<input type="text" value="1500"/> Gallons	in <input type="text" value="1"/> Tanks or Compartments
Recommended Septic Tank Capacity:	<input type="text" value="1790"/> Gallons	in <input type="text" value="3"/> Tanks or Compartments
Effluent Screen & Alarm (Y/N):	<input type="text" value="Optional"/> Model/Type: <input type="text"/>	
B. Other Establishments:		
Waste received by:	<input type="text"/>	<input type="text"/> GPD x <input type="text"/> Days Hyd. Retention Time
Code Minimum Septic Tank Capacity:	<input type="text"/> Gallons	in <input type="text"/> Tanks or Compartments
Recommended Septic Tank Capacity:	<input type="text"/> Gallons	in <input type="text"/> Tanks or Compartments
Effluent Screen & Alarm (Y/N):	<input type="text"/> Model/Type: <input type="text"/>	
5. PUMP TANK SIZING		
Pump Tank 1 Capacity (Minimum):	<input type="text" value="600"/> Gal	Pump Tank 2 Capacity (Minimum): <input type="text"/> Gal
Pump Tank 1 Capacity (Recommended):	<input type="text" value="1060"/> Gal	Pump Tank 2 Capacity (Recommended): <input type="text"/> Gal
Pump 1 <input type="text" value="18.0"/> GPM	Total Head <input type="text" value="15.7"/> ft	Pump 2 <input type="text"/> GPM Total Head <input type="text"/> ft
Supply Pipe Dia. <input type="text" value="2.00"/> in	Dose Vol: <input type="text" value="50.0"/> gal	Supply Pipe Dia. <input type="text"/> Dose Vol: <input type="text"/> Gal

6. SYSTEM AND DISTRIBUTION TYPE		Project ID: _____	
Soil Treatment Type:	<input type="text" value="Mound"/>	Distribution Type:	<input type="text" value="Pressure Distribution-Level"/>
Elevation Benchmark:	<input type="text" value="100"/> ft	Benchmark Location:	<input type="text" value="Pump Compartment MH cover"/>
MPCA System Type:	<input type="text" value="Type III"/>	Distribution Media:	<input type="text" value="Rock"/>
Type III/IV Details:	<input type="text" value="Dig out to level bed/Time Dosed"/>		

7. SITE EVALUATION SUMMARY:

Describe Limiting Condition:

Layers with >35% Rock Fragments? (yes/no) If yes, describe below: % rock and layer thickness, amount of soil credit and any additional information for addressing the rock fragments in this design.

Note:

	Depth	Depth	Elevation of Limiting Condition
Limiting Condition:	<input type="text" value="26"/> inches	<input type="text" value="2.2"/> ft	<input type="text" value=""/>
Minimum Req'd Separation:	<input type="text" value="36"/> inches	<input type="text" value="3.0"/> ft	<input type="text" value=""/> Elevation <i>Critical for system compliance</i>
Code Max System Depth:	<input type="text" value="Mound"/> inches	<input type="text" value="-0.8"/> ft	<input type="text" value=""/> ft

This is the maximum depth to the bottom of the distribution media for required separation. Negative Depth (ft) means it must be a mound.

Soil Texture:

Soil Hyd. Loading Rate: GPD/ft² Percolation Rate: MPI

Contour Loading Rate: Note:

Measured Land Slope: % Note:

Comments:

8. SOIL TREATMENT AREA DESIGN SUMMARY

Trench:

Dispersal Area	<input type="text" value=""/>	ft ²	Sidewall Depth	<input type="text" value=""/>	in	Trench Width	<input type="text" value=""/>	ft
Total Lineal Feet	<input type="text" value=""/>	ft	No. of Trenches	<input type="text" value=""/>		Code Max. Trench Depth	<input type="text" value=""/>	in
Contour Loading Rate	<input type="text" value=""/>	ft	Length	<input type="text" value=""/>	ft	Designed Trench Depth	<input type="text" value=""/>	in

Bed:

Dispersal Area	<input type="text" value=""/>	ft ²	Sidewall Depth	<input type="text" value=""/>	in	Maximum Bed Depth	<input type="text" value=""/>	in
Bed Width	<input type="text" value=""/>	ft	Bed Length	<input type="text" value=""/>	ft	Designed Bed Depth	<input type="text" value=""/>	in

Mound:

Dispersal Area	<input type="text" value="250.0"/>	ft ²	Bed Length	<input type="text" value="25.0"/>	ft	Bed Width	<input type="text" value="10.0"/>	ft
Absorption Width	<input type="text" value="10.0"/>	ft	Clean Sand Lift	<input type="text" value="1.0"/>	ft	Berm Width (0-1%)	<input type="text" value="12.2"/>	ft
Upslope Berm Width	<input type="text" value="10.2"/>	ft	Downslope Berm	<input type="text" value="15.3"/>	ft	Endslope Berm Width	<input type="text" value="12.2"/>	ft
Total System Length	<input type="text" value="49.4"/>	ft	System Width	<input type="text" value="35.4"/>	ft	Contour Loading Rate	<input type="text" value="12.0"/>	gal/ft

Project ID: _____

At-Grade:

Bed Width <input style="width: 80%;" type="text"/> ft	Bed Length <input style="width: 80%;" type="text"/> ft	Finished Height <input style="width: 80%;" type="text"/> ft
Contour Loading Rate <input style="width: 80%;" type="text"/> gal/ft	Upslope Berm <input style="width: 80%;" type="text"/> ft	Downslope Berm <input style="width: 80%;" type="text"/> ft
Endslope Berm <input style="width: 80%;" type="text"/> ft	System Length <input style="width: 80%;" type="text"/> ft	System Width <input style="width: 80%;" type="text"/> ft

Level & Equal Pressure Distribution

No. of Laterals <input style="width: 80%;" type="text" value="3"/>	Perforation Spacing <input style="width: 80%;" type="text" value="3"/> ft	Perforation Diameter <input style="width: 80%;" type="text" value="1/4"/> in
Lateral Diameter <input style="width: 80%;" type="text" value="1.50"/> in	Min Dose Volume <input style="width: 80%;" type="text" value="30"/> gal	Max Dose Volume <input style="width: 80%;" type="text" value="75"/> gal

Non-Level and Unequal Pressure Distribution

	Elevation (ft)	Pipe Size (in)	Pipe Volume (gal/ft)	Pipe Length (ft)	Perf Size (in)	Spacing (ft)	Spacing (in)	
Lateral 1								Minimum Dose Volume <input style="width: 80%;" type="text"/> gal
Lateral 2								
Lateral 3								
Lateral 4								Maximum Dose Volume <input style="width: 80%;" type="text"/> gal
Lateral 5								
Lateral 6								

9. Additional Info for At-Risk, HSW or Type IV Design

A. Starting BOD Concentration = Design Flow X Starting BOD (mg/L) X 8.35 ÷ 1,000,000

gpd X mg/L X 8.35 ÷ 1,000,000 = lbs. BOD/day

B. Target BOD Concentration = Design Flow X Target BOD (mg/L) X 8.35 ÷ 1,000,000

gpd X mg/L X 8.35 ÷ 1,000,000 = lbs. BOD/day

Lbs. BOD To Be Removed:

PreTreatment Technology: *Must Meet or Exceed Target

Disinfection Technology: *Required for Levels A & B

C. Organic Loading to Soil Treatment Area:

mg/L X gpd x 8.35 ÷ 1,000,000 ÷ ft² = lbs./day/ft²

10. Comments/Special Design Considerations:

I hereby certify that I have completed this work in accordance with all applicable ordinances, rules and laws.

Melissa Besser		2624	11/11/2020
(Designer)	(Signature)	(License #)	(Date)

Mound Design Worksheet

<1% Slope

1. **SYSTEM SIZING:** Project ID: _____ v 04.01.2020

A. Design Flow : GPD

B. Soil Loading Rate: GPD/ft²

C. Depth to Limiting Condition: ft

D. Percent Land Slope: %

E. Design Media Loading Rate: GPD/ft²

F. Mound Absorption Ratio:

TABLE IXa				
LOADING RATES FOR DETERMINING BOTTOM ABSORPTION AREA AND ABSORPTION RATIOS USING PERCOLATION TESTS				
Percolation Rate (MPI)	Treatment Level C		Treatment Level A, A-2, B,	
	Absorption Area Loading Rate (gpd/ft ²)	Mound Absorption Ratio	Absorption Area Loading Rate (gpd/ft ²)	Mound Absorption Ratio
<0.1	-	1	-	1
0.1 to 5	1.2	1	1.6	1
0.1 to 5 (fine sand and loamy fine sand)	0.6	2	1	1.6
6 to 15	0.78	1.5	1	1.6
16 to 30	0.6	2	0.78	2
31 to 45	0.5	2.4	0.78	2
46 to 60	0.45	2.6	0.6	2.6
61 to 120	-	5	0.3	5.3
>120	-	-	-	-

Table I MOUND CONTOUR LOADING RATES:				
Measured Perc Rate	← OR →	Texture - derived mound absorption ratio		Contour Loading Rate:
≤ 60mpi		1.0, 1.3, 2.0, 2.4, 2.6	→	≤12
61-120 mpi	← OR →	5.0	→	≤12
≥ 120 mpi*		>5.0*	→	≤6*

*Systems with these values are not Type I systems. Contour Loading Rate (linear loading rate) is a recommended value.

2. **DISPERSAL MEDIA SIZING**

A. Calculate Dispersal Bed Area: Design Flow (1.A) ÷ Design Media Loading Rate

GPD ÷ GPD/ft² = ft²

If a larger dispersal media area is desired, enter size: ft²

B. Enter Dispersal Bed Width: ft *Can not exceed 10 feet.*

C. Calculate Contour Loading Rate: Bed Width X Design Media Loading Rate

ft² X GPD/ft² = gal/ft *Can not exceed Table 1*

D. Calculate Minimum Dispersal Bed Length: Dispersal Bed Area ÷ Bed Width

ft² ÷ ft = ft

3. **ABSORPTION AREA SIZING**

A. Calculate Absorption Width: Bed Width X Mound Absorption Ratio

ft X = ft

B. For slopes from 0 to 1%, the Absorption Width is measured from the bed equally in both directions.

Absorption Width Beyond the Bed: Absorption Width - Bed Width ÷ 2

(ft - ft) ÷ 2 = ft

4. DISTRIBUTION MEDIA: ROCK

Project ID:

A. Rock Depth Below Distribution Pipe

in ft

5. DISTRIBUTION MEDIA: REGISTERED TREATMENT PRODUCTS: CHAMBERS AND EZFLOW**A. Enter Dispersal Media:**

B. Enter the Component: Length: ft **Width:** ft **Depth:** ft**C. Number of Components per Row = Bed Length divided by Component Length (Round up)**

ft ÷ ft = components/row

Check registered product information for specific application and design

D. Actual Bed Length = Number of Components/row X Component Length:

components X ft =

E. Number of Rows = Bed Width divided by Component Width

ft ÷ ft = rows *Adjust width so this is a whole number.*

F. Total Number of Components = Number of Components per Row X Number of Rows

X = components

6. MOUND SIZING**A. Clean Sand Lift: Required Separation - Depth to Limiting Condition = Clean Sand Lift (1 ft minimum)**

ft - ft = ft Design Sand Lift (optional):

B. Upslope Height = Clean Sand Lift + Depth of Media + Depth to Cover Pipe + Depth of Cover (1 ft)

ft + ft + ft + ft = ft

C. Berm Width = Upslope Mound Height X 4 (4 is recommended, but could be 3-12)

ft X ft = ft

D. Total Landscape Width = Berm Width + Dispersal Bed Width + Berm Width

ft + ft + ft = ft

E. Additional Berm Width necessary for absorption - Absorption Width - Total Landscape Width

ft - ft = ft if number is negative (<0), value is ZERO

F. Final Berm Width = Additional Berm Width + Berm Width

ft + ft = ft

G. Total Mound Width = Final Berm Width + Dispersal Bed Width + Final Berm Width

ft + ft + ft = ft

H. Total Mound Length = Final Berm Width + Dispersal Bed Length + Final Berm Width

ft + ft + ft = ft

I. Setbacks from the Bed: Absorption Width - Dispersal Bed Width divided by 2

(ft -) / 2 = ft

7. MOUND DIMENSIONS

Project ID:

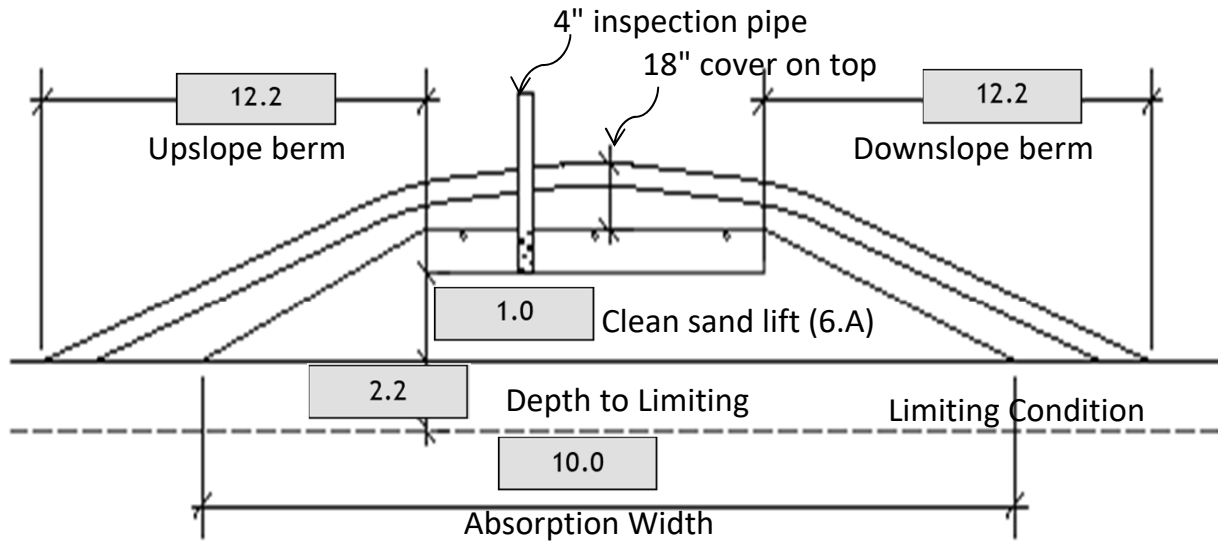
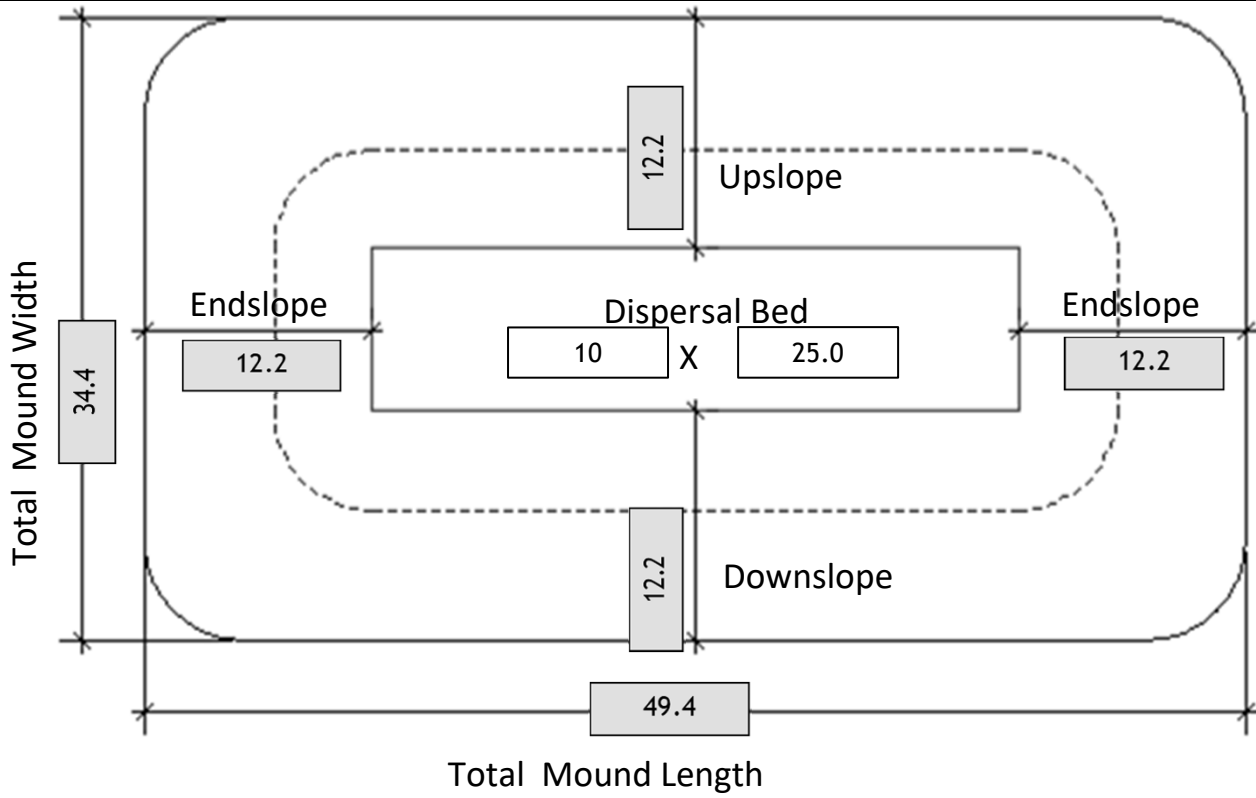

Comments:



Mound Materials Worksheet

Project ID:

v 04.01.2020

A. Rock Volume: (Rock Below Pipe + Rock to cover pipe (pipe outside dia + ~2 inch)) X Bed Length X Bed Width = Volume

$$\left(\boxed{9} \text{ in} + \boxed{3.0} \text{ in} \right) \div 12 \times \boxed{25.0} \text{ ft} \times \boxed{10.0} \text{ ft} = \boxed{250.0} \text{ ft}^3$$

Divide ft³ by 27 ft³/yd³ to calculate cubic yards: $\boxed{250.0} \text{ ft}^3 \div 27 = \boxed{9.3} \text{ yd}^3$

Add 30% for constructability: $\boxed{9.3} \text{ yd}^3 \times 1.3 = \boxed{12.0} \text{ yd}^3$

B. Calculate Clean Sand Volume:

Volume Under Rock bed: Average Sand Depth x Media Width x Media Length = cubic feet

$$\boxed{1.1} \text{ ft} \times \boxed{10.0} \text{ ft} \times \boxed{25.0} \text{ ft} = \boxed{262.5} \text{ ft}^3$$

For a Mound on a slope from 0-1%

Volume from Length = ((Upslope Mound Height - 1) X Absorption Width Beyond Bed X Media Bed Length)

$$\boxed{3.05} \text{ ft} - 1) \times \boxed{} \times \boxed{25} \text{ ft} = \boxed{6.00}$$

Volume from Width = ((Upslope Mound Height - 1) X Absorption Width Beyond Bed X Media Bed Width)

$$\boxed{3.05} \text{ ft} - 1) \times \boxed{} \times \boxed{10} \text{ ft} = \boxed{6.00}$$

Total Clean Sand Volume: Volume from Length + Volume from Width + Volume Under Media

$$\boxed{6.0} \text{ ft}^3 + \boxed{6.0} \text{ ft}^3 + \boxed{262.5} \text{ ft}^3 = \boxed{274.5} \text{ ft}^3$$

For a Mound on a slope greater than 1%

Upslope Volume: ((Upslope Mound Height - 1) x 3 x Bed Length) ÷ 2 = cubic feet

$$\left(\boxed{3.1} \text{ ft} - 1 \right) \times 3.0 \text{ ft} \times \boxed{25.0} \div 2 = \boxed{76.9} \text{ ft}^3$$

Downslope Volume: ((Downslope Height - 1) x Downslope Absorption Width x Media Length) ÷ 2 = cubic feet

$$\left(\boxed{3.1} \text{ ft} - 1 \right) \times \boxed{} \text{ ft} \times \boxed{25.0} \div 2 = \boxed{} \text{ ft}^3$$

Endslope Volume: (Downslope Mound Height - 1) x 3 x Media Width = cubic feet

$$\left(\boxed{3.1} \text{ ft} - 1 \right) \times 3.0 \text{ ft} \times \boxed{10.0} \text{ ft} = \boxed{61.5} \text{ ft}^3$$

Total Clean Sand Volume: Upslope Volume + Downslope Volume + Endslope Volume + Volume Under Media

$$\boxed{76.9} \text{ ft}^3 + \boxed{} \text{ ft}^3 + \boxed{61.5} \text{ ft}^3 + \boxed{262.5} \text{ ft}^3 = \boxed{400.9} \text{ ft}^3$$

Divide ft³ by 27 ft³/yd³ to calculate cubic yards: $\boxed{400.9} \text{ ft}^3 \div 27 = \boxed{14.8} \text{ yd}^3$

Add 30% for constructability: $\boxed{14.8} \text{ yd}^3 \times 1.3 = \boxed{19.3} \text{ yd}^3$

C. Calculate Sandy Berm Volume:

Total Berm Volume (approx): ((Avg. Mound Height - 0.5 ft topsoil) x Mound Width x Mound Length) ÷ 2

$$\left(\boxed{3.1} - 0.5 \right) \text{ ft} \times \boxed{35.4} \text{ ft} \times \boxed{49.4} \div 2 = \boxed{2230.1} \text{ ft}^3$$

Total Mound Volume - Clean Sand volume - Rock Volume = cubic feet

$$\boxed{2230.1} \text{ ft}^3 - \boxed{400.9} \text{ ft}^3 - \boxed{250.0} \text{ ft}^3 = \boxed{1579.2} \text{ ft}^3$$

Divide ft³ by 27 ft³/yd³ to calculate cubic yards: $\boxed{1579.2} \text{ ft}^3 \div 27 = \boxed{58.5} \text{ yd}^3$

Add 30% for constructability: $\boxed{58.5} \text{ yd}^3 \times 1.3 = \boxed{76.0} \text{ yd}^3$

D. Calculate Topsoil Material Volume: Total Mound Width X Total Mound Length X .5 ft

$$\boxed{35.4} \text{ ft} \times \boxed{49.4} \text{ ft} \times 0.5 \text{ ft} = \boxed{874.5} \text{ ft}^3$$

Divide ft³ by 27 ft³/yd³ to calculate cubic yards: $\boxed{874.5} \text{ ft}^3 \div 27 = \boxed{32.4} \text{ yd}^3$

Add 30% for constructability: $\boxed{32.4} \text{ yd}^3 \times 1.3 = \boxed{42.1} \text{ yd}^3$

Project ID:

v 04.01.2020

- Media Bed Width: ft
- Minimum Number of Laterals in system/zone = Rounded up number of $[(\text{Media Bed Width} - 4) \div 3] + 1$.

$$[(\text{ } \boxed{10} \text{ } - 4) \div 3] + 1 = \text{ } \boxed{3} \text{ } \text{laterals} \quad \text{Does not apply to at-grades}$$
- Designer Selected Number of Laterals: laterals
Cannot be less than line 2 (Except in at-grades)
- Select Perforation Spacing: ft
- Select Perforation Diameter Size: in
- Length of Laterals = Media Bed Length - 2 Feet.

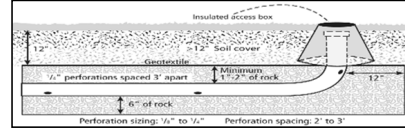

- 2ft = ft *Perforation can not be closer than 1 foot from edge.*

- Determine the Number of Perforation Spaces. Divide the Length of Laterals by the Perforation Spacing and round down to the nearest whole number.

$$\text{Number of Perforation Spaces} = \text{ } \boxed{23.0} \text{ } \text{ft} \div \text{ } \boxed{3.0} \text{ } \text{ft} = \text{ } \boxed{7} \text{ } \text{Spaces}$$
- Number of Perforations per Lateral is equal to 1.0 plus the Number of Perforation Spaces. Check table below to verify the number of perforations per lateral guarantees less than a 10% discharge variation. The value is double with a center manifold.

$$\text{Perforations Per Lateral} = \text{ } \boxed{7} \text{ } \text{Spaces} + 1 = \text{ } \boxed{8} \text{ } \text{Perfs. Per Lateral}$$

Maximum Number of Perforations Per Lateral to Guarantee <10% Discharge Variation											
1/4 Inch Perforations						7/32 Inch Perforations					
Perforation Spacing (Feet)	Pipe Diameter (Inches)					Perforation Spacing (Feet)	Pipe Diameter (Inches)				
	1	1 1/4	1 1/2	2	3		1	1 1/4	1 1/2	2	3
2	10	13	18	30	60	2	11	16	21	34	68
2 1/2	8	12	16	28	54	2 1/2	10	14	20	32	64
3	8	12	16	25	52	3	9	14	19	30	60
3/16 Inch Perforations						1/8 Inch Perforations					
Perforation Spacing (Feet)	Pipe Diameter (Inches)					Perforation Spacing (Feet)	Pipe Diameter (Inches)				
	1	1 1/4	1 1/2	2	3		1	1 1/4	1 1/2	2	3
2	12	18	26	46	87	2	21	33	44	74	149
2 1/2	12	17	24	40	80	2 1/2	20	30	41	69	135
3	12	16	22	37	75	3	20	29	38	64	128

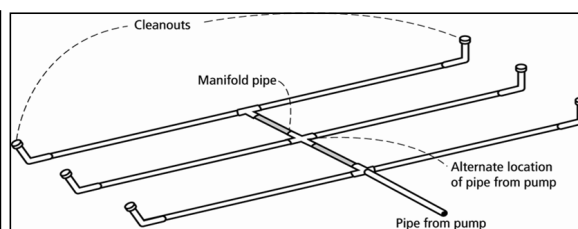
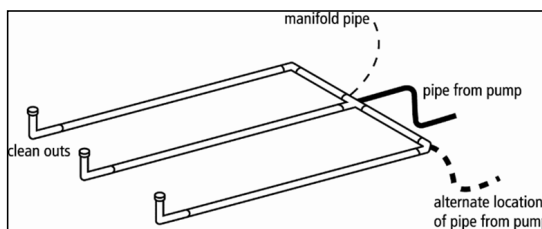

- Total Number of Perforations equals the Number of Perforations per Lateral multiplied by the Number of Perforated Laterals.

$$\text{ } \boxed{8} \text{ } \text{Perf. Per Lat.} \times \text{ } \boxed{3} \text{ } \text{Number of Perf. Lat.} = \text{ } \boxed{24} \text{ } \text{Total Number of Perf.}$$

- Spacing of laterals; Must be greater than 1 foot and no more than 3 feet: ft
- Select Type of Manifold Connection (End or Center):
- Select Lateral Diameter (See Table): in

13. Calculate the **Square Feet per Perforation**.

Recommended value is 4-11 ft² per perforation, Does not apply to At-Grades

a. **Bed Area** = Bed Width (ft) X Bed Length (ft)

ft X ft = ft²

b. **Square Foot per Perforation** = Bed Area ÷ by the Total Number of Perfs

ft² ÷ perf = ft²/perf

14. Select **Minimum Average Head** :

ft

15. Select **Perforation Discharge** based on Table:

GPM per Perf

16. **Flow Rate** = Total Number of Perfs X Perforation Discharge.

Perfs X GPM per Perforation = GPM

17. **Volume of Liquid Per Foot of Distribution Piping (Table II)** :

Gallons/ft

18. **Volume of Distribution Piping** =

= [Number of Perforated Laterals X Length of Laterals X (Volume of Liquid Per Foot of Distribution Piping)]

X ft X gal/ft = Gallons

19. **Minimum Delivered Volume** = Volume of Distribution Piping X 4

gals X 4 = Gallons

Perforation Discharge (GPM)				
Head (ft)	Perforation Diameter			
	1/8	3/16	7/32	1/4
1.0 ^a	0.18	0.41	0.56	0.74
1.5	0.22	0.51	0.69	0.9
2.0 ^b	0.26	0.59	0.80	1.04
2.5	0.29	0.65	0.89	1.17
3.0	0.32	0.72	0.98	1.28
4.0	0.37	0.83	1.13	1.47
5.0 ^c	0.41	0.93	1.26	1.65
1 foot	Dwellings with 3/16 inch to 1/4 inch perforations			
2 feet	Dwellings with 1/8 inch perforations			
2 feet	Other establishments and MSTs with 3/16 inch to 1/4 inch perforations			
5 feet	Other establishments and MSTs with 1/8 inch perforations			

Pipe Diameter (inches)	Liquid Per Foot (Gallons)
1	0.045
1.25	0.078
1.5	0.110
2	0.170
3	0.380
4	0.661

Comments/Special Design Considerations:

1. PUMP CAPACITY

Project ID:

v 04.01.2020

Pumping to Gravity or Pressure Distribution:

Pressure

A. If pumping to gravity enter the gallon per minute of the pump:

GPM (10 - 45 gpm)

B. If pumping to a pressurized distribution system:

18.0

GPM

C. Enter pump description:

Equalization/Time Dosing

2. HEAD REQUIREMENTS

A. Elevation Difference ft
between pump and point of discharge:

B. Distribution Head Loss: ft

C. Additional Head Loss: ft (due to special equipment, etc.)

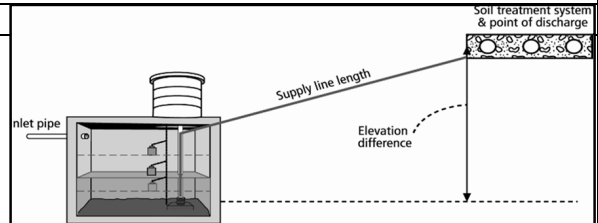

Distribution Head Loss	
Gravity Distribution = 0ft	
Pressure Distribution based on Minimum Average Head Value on Pressure Distribution Worksheet:	
Minimum Average Head	Distribution Head Loss
1ft	5ft
2ft	6ft
5ft	10ft

Table I. Friction Loss in Plastic Pipe per 100ft

Flow Rate (GPM)	Pipe Diameter (inches)			
	1	1.25	1.5	2
10	9.1	3.1	1.3	0.3
12	12.8	4.3	1.8	0.4
14	17.0	5.7	2.4	0.6
16	21.8	7.3	3.0	0.7
18		9.1	3.8	0.9
20		11.1	4.6	1.1
25		16.8	6.9	1.7
30		23.5	9.7	2.4
35			12.9	3.2
40			16.5	4.1
45			20.5	5.0
50				6.1
55				7.3
60				8.6
65				10.0
70				11.4
75				13.0
85				16.4
95				20.1

D. 1. Supply Pipe Diameter: in

2. Supply Pipe Length: ft

E. Friction Loss in Plastic Pipe per 100ft from Table I:

Friction Loss = ft per 100ft of pipe

F. Determine *Equivalent Pipe Length* from pump discharge to soil dispersal area discharge point. Estimate by adding 25% to supply pipe length for fitting loss. *Supply Pipe Length X 1.25 = Equivalent Pipe Length*

ft X 1.25 = ft

G. Calculate *Supply Friction Loss* by multiplying *Friction Loss Per 100ft* by the *Equivalent Pipe Length* and divide by 100.

Supply Friction Loss =

ft per 100ft X ft ÷ 100 = ft

H. *Total Head* requirement is the sum of the *Elevation Difference* + *Distribution Head Loss*, + *Additional Head Loss* + *Supply Friction Loss*

ft + ft + ft + ft = ft

3. PUMP SELECTION

A pump must be selected to deliver at least **18.0** GPM with at least **15.7** feet of total head.

Comments:

Blank area for comments.

DETERMINE TANK CAPACITY AND DIMENSIONS

Project ID:

v 04.01.2020

1. A. Design Flow (Design Sum. 1A): GPD B. Tank Use:
- C. Percentage of Design Flow % Gal Up to 75% design flow is normal for Design percentage
- D. Min. required pump tank capacity: Gal E. Recommended capacity: Gal

2. A. Tank Manufacturer: B. Tank Model:
- C. Capacity from manufacturer: Gallons *Note: Design calculations are based on this specific tank. Substituting a different tank model will change the pump float or timer settings. Contact designer if changes are necessary.*
- D. Gallons per inch: Gallons per inch
- E. Liquid depth of tank from manufacturer: inches

DETERMINE DOSING VOLUME

3. Volume to Cover Pump (The inlet of pump should be 4 in from the bottom of the tank & 2 in covering the pump recommended)

(Pump and block height + 2 inches) X Gallons Per Inch

(in + 2 inches) X Gallons Per In = Gallons

4. Minimum Delivered Volume = 4 X Volume of Distribution Piping:

-Item 18 of the Pressure Distribution or Item 11 of Non-level Gallons (minimum dose) inches/dose

5. Calculate Maximum Pumpout Volume (25% of Design Flow)

Design Flow: GPD X 0.25 = Gallons (maximum dose) inches/dose

6. Select a pumpout volume that meets both Minimum and Maximum: Gallons

7. Calculate Doses Per Day = Percentage Design Flow ÷ Delivered Volume

gpd ÷ gal = Doses

8. Calculate Drainback:

A. Diameter of Supply Pipe = inches

B. Length of Supply Pipe = feet

C. Volume of Liquid Per Lineal Foot of Pipe = Gallons/ft

D. Drainback = Length of Supply Pipe X Volume of Liquid Per Lineal Foot of Pipe

ft X gal/ft = Gallons

9. Total Dosing Volume = Delivered Volume plus Drainback

gal + gal = Gallons

10. Working Storage Volume = Tank Volume - Volume to Cover Pump - Reserve Capacity

gal - gal - = Gallons

Volume of Liquid in Pipe	
Pipe Diameter (inches)	Liquid Per Foot (Gallons)
1	0.045
1.25	0.078
1.5	0.110
2	0.170
3	0.380
4	0.661

11. Required Flow Rate :

A. From Pump Curve - Must verify after Install: GPM*

- B. Calculated GPM = Change in Depth (in) x Gallons Per Inch / Time Interval in Minutes

in X gal/in ÷ min = GPM

12. Select Flow Rate from Line 11.A or 11.B: GPM*

**Note: This value must be adjusted after installation based on pump calibration.*

NORMAL OPERATION TIMER SETTINGS*

13. Calculate **TIMER ON** setting*:

Total Dosing Volume ÷ GPM

$$\boxed{60} \text{ gal} \div \boxed{18.0} \text{ gpm} = \boxed{3.3} \text{ Minutes ON}^*$$

HR	MIN	SEC
0	3.0	20

14. Calculated **TIMER OFF** setting*:

Minutes Per Day (1440)/Doses Per Day - Minutes On

$$1440 \text{ min} \div \boxed{4} \text{ doses/day} - \boxed{3.3} \text{ min} = \boxed{339.5} \text{ Minutes OFF}^*$$

HR	MIN	SEC
5	39.0	31

OPTIONAL PEAK ENABLE DOSING* - Desingers option for peak flow operation

15. Peak Percentage of Design Flow %

16. Peak Pump Volume that meets both Minimum and Maximum Volume gal + DrainBack 10.2 gal

17. Peak Dose Volume gal

HR	MIN	SEC
<input type="text"/>	<input type="text"/>	<input type="text"/>

18. Peak TIMER ON gal ÷ gpm = min ON

HR	MIN	SEC
<input type="text"/>	<input type="text"/>	<input type="text"/>

**Note: This value must be adjusted after installation based on pump calibration.*

19. Peak TIMER OFF: 1440 min ÷ doses/day - min On min Off

HR	MIN	SEC
<input type="text"/>	<input type="text"/>	<input type="text"/>

FLOAT SETTINGS

20. Pump Off Float - Measuring from bottom of tank:

Distance to set Pump Off Float = Gallons to Cover Pump / Gallons Per Inch:

$$\boxed{336} \text{ gal} \div \boxed{24.0} \text{ gal/in} = \boxed{14.0} \text{ Inches}$$

21. Alarm Float - Measuring from bottom of tank (90% recommended):

Distance to set Alarm Float = Tank Depth X % of Tank Depth (0.9 recommended)

$$\boxed{44.0} \text{ in} \times \boxed{70} \% = \boxed{30.8} \text{ Inches}$$

22. Reserve Capacity in gallons = (Tank Depth - Alarm Depth) X GPI

$$(\boxed{44.0} \text{ in} + \boxed{30.8} \text{ in}) \times \boxed{24.0} = \boxed{316.8} \text{ gallons}$$

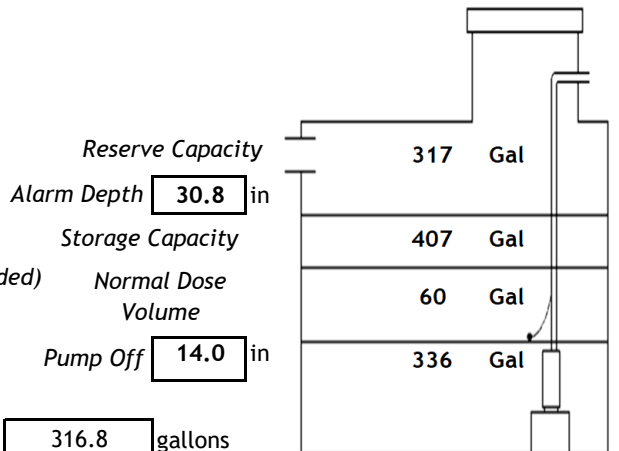

Soil Observation Log

Property Owner		Patrick & Jane Jacobwith			Property Address		49131 373rd Place - Palisade, MN 56469		
Soil parent material(s): (Check all that apply)									
<input checked="" type="checkbox"/> Outwash <input type="checkbox"/> Lacustrine <input type="checkbox"/> Loess <input type="checkbox"/> Till <input type="checkbox"/> Alluvium <input type="checkbox"/> Bedrock <input type="checkbox"/> Organic Matter									
Landscape Position: (check one)									
<input type="checkbox"/> Summit <input type="checkbox"/> Shoulder <input type="checkbox"/> Back/Side Slope <input type="checkbox"/> Foot Slope <input type="checkbox"/> Toe Slope									
Vegetation		Grass		Soil survey map units			B39A - Meehan Loamy Sand		
Weather Conditions/Time of Day:			Sunny 12:30pm				Date		11/03/20
Observation #/Location:		Soil Boring 1				Observation Type:		Auger	
Depth (in)	Texture	Rock Frag. %	Matrix Color(s)	Mottle Color(s)	Redox Kind(s)	Indicator(s)	----- Structure-----		
							Shape	Grade	Consistence
0" - 2"	Loamy Sand	<35%	10YR 3/2				Granular	Strong	Friable
2" - 10"	Loamy Sand	<35%	10YR 3/3				Granular	Structureless	Loose
10" - 28"	Sand	<35%	10YR 4/6				Single grain	Structureless	Loose
28" - 30"	Sand	<35%	10YR 4/6	10YR 5/8	Concentrations, depletions	S2	Single grain	Structureless	Loose
Observation #/Location:		Soil Boring 2				Observation Type:		Auger	
0" - 3"	Loamy Sand	<35%	10YR 3/2				Granular	Strong	Friable
3" - 11"	Loamy Sand	<35%	10YR 3/3				Granular	Structureless	Loose
11" - 26"	Sand	<35%	10YR 4/6				Single grain	Structureless	Loose
26" - 28"	Sand	<35%	10YR 4/6	10YR 5/8	Concentrations, depletions	S2	Single grain	Structureless	Loose
Observation #/Location:		Soil Boring 3				Observation Type:		Auger	
0" - 5"	Loamy Sand	<35%	10YR 3/2				Granular	Strong	Friable
5" - 28"	Sand	<35%	10YR 4/6				Single grain	Structureless	Loose
28" - 30"	Sand	<35%	10YR 4/6		Concentrations, depletions	S2	Single grain	Structureless	Loose
Comments									
I hereby certify that I have completed this work in accordance with all applicable ordinances, rules and laws.									
Melissa Besser						2624		11/11/2020	
(Designer/Inspector)			(Signature)			(License #)		(Date)	

Aitkin County, Minnesota

B39A—Meehan loamy sand, 0 to 3 percent slopes

Map Unit Setting

National map unit symbol: 2x141

Elevation: 590 to 2,030 feet

Mean annual precipitation: 23 to 33 inches

Mean annual air temperature: 36 to 48 degrees F

Frost-free period: 90 to 170 days

Farmland classification: Not prime farmland

Map Unit Composition

Meehan and similar soils: 84 percent

Minor components: 16 percent

Estimates are based on observations, descriptions, and transects of the mapunit.

Description of Meehan

Setting

Landform: Flats

Landform position (three-dimensional): Talf

Down-slope shape: Linear

Across-slope shape: Linear

Parent material: Sandy outwash

Typical profile

A - 0 to 7 inches: loamy sand

Bw - 7 to 28 inches: sand

C - 28 to 79 inches: sand

Properties and qualities

Slope: 0 to 3 percent

Surface area covered with cobbles, stones or boulders: 0.0 percent

Depth to restrictive feature: More than 80 inches

Drainage class: Somewhat poorly drained

Capacity of the most limiting layer to transmit water (Ksat): High to very high (2.00 to 20.00 in/hr)

Depth to water table: About 12 to 28 inches

Frequency of flooding: None

Frequency of ponding: None

Maximum salinity: Nonsaline to very slightly saline (0.0 to 2.0 mmhos/cm)

Available water capacity: Low (about 4.7 inches)

Interpretive groups

Land capability classification (irrigated): 4e

Land capability classification (nonirrigated): 4w

Hydrologic Soil Group: A/D

Ecological site: F057XY015MN - Wet Mixed Forest

Forage suitability group: Level Swale, Low AWC, Acid
(G057XN007MN)
Other vegetative classification: Level Swale, Low AWC, Acid
(G057XN007MN)
Hydric soil rating: No

Minor Components

Roscommon

Percent of map unit: 6 percent
Landform: Flats
Landform position (three-dimensional): Dip
Down-slope shape: Concave
Across-slope shape: Linear
Other vegetative classification: Level Swale, Low AWC, Acid
(G057XN007MN)
Hydric soil rating: Yes

Wurtsmith

Percent of map unit: 4 percent
Landform: Flats
Landform position (three-dimensional): Rise
Down-slope shape: Convex
Across-slope shape: Linear
Other vegetative classification: Sloping Upland, Low AWC, Acid
(G057XN008MN)
Hydric soil rating: No

Karlstad

Percent of map unit: 2 percent
Landform: Flats
Landform position (three-dimensional): Rise
Down-slope shape: Convex
Across-slope shape: Linear
Other vegetative classification: Sloping Upland, Low AWC, Neutral
(G057XN004MN)
Hydric soil rating: No

Menahga

Percent of map unit: 2 percent
Landform: Flats
Landform position (three-dimensional): Rise
Down-slope shape: Convex
Across-slope shape: Linear
Other vegetative classification: Sandy (G057XN022MN)
Hydric soil rating: No

Leafriver, frequently ponded

Percent of map unit: 2 percent
Landform: Depressions
Landform position (three-dimensional): Dip
Down-slope shape: Concave
Across-slope shape: Concave
Other vegetative classification: Organic (G057XN014MN)

Hydric soil rating: Yes

Data Source Information

Soil Survey Area: Aitkin County, Minnesota
Survey Area Data: Version 21, Jun 4, 2020

Soil Map—Aitkin County, Minnesota



Soil Map may not be valid at this scale.

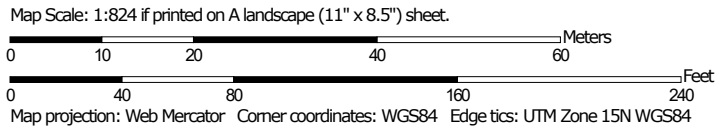



MAP LEGEND

Area of Interest (AOI)

 Area of Interest (AOI)

Soils

 Soil Map Unit Polygons

 Soil Map Unit Lines

 Soil Map Unit Points

Special Point Features



Blowout



Borrow Pit



Clay Spot



Closed Depression



Gravel Pit



Gravelly Spot



Landfill



Lava Flow



Marsh or swamp



Mine or Quarry



Miscellaneous Water



Perennial Water



Rock Outcrop



Saline Spot



Sandy Spot



Severely Eroded Spot



Sinkhole



Slide or Slip



Sodic Spot



Spoil Area



Stony Spot



Very Stony Spot



Wet Spot



Other



Special Line Features

Water Features



Streams and Canals

Transportation



Rails



Interstate Highways



US Routes



Major Roads



Local Roads

Background



Aerial Photography

MAP INFORMATION

The soil surveys that comprise your AOI were mapped at 1:20,000.

Warning: Soil Map may not be valid at this scale.

Enlargement of maps beyond the scale of mapping can cause misunderstanding of the detail of mapping and accuracy of soil line placement. The maps do not show the small areas of contrasting soils that could have been shown at a more detailed scale.

Please rely on the bar scale on each map sheet for map measurements.

Source of Map: Natural Resources Conservation Service

Web Soil Survey URL:

Coordinate System: Web Mercator (EPSG:3857)

Maps from the Web Soil Survey are based on the Web Mercator projection, which preserves direction and shape but distorts distance and area. A projection that preserves area, such as the Albers equal-area conic projection, should be used if more accurate calculations of distance or area are required.

This product is generated from the USDA-NRCS certified data as of the version date(s) listed below.

Soil Survey Area: Aitkin County, Minnesota

Survey Area Data: Version 21, Jun 4, 2020

Soil map units are labeled (as space allows) for map scales 1:50,000 or larger.

Date(s) aerial images were photographed: Jun 12, 2014—Aug 23, 2016

The orthophoto or other base map on which the soil lines were compiled and digitized probably differs from the background imagery displayed on these maps. As a result, some minor shifting of map unit boundaries may be evident.

Map Unit Legend

Map Unit Symbol	Map Unit Name	Acres in AOI	Percent of AOI
546	Lupton muck	1.0	32.4%
B39A	Meehan loamy sand, 0 to 3 percent slopes	1.9	63.0%
W	Water	0.1	4.6%
Totals for Area of Interest		3.0	100.0%



Septic System Management Plan for Above Grade Systems

The goal of a septic system is to protect human health and the environment by properly treating wastewater before returning it to the environment. Your septic system is designed to kill harmful organisms and remove pollutants before the water is recycled back into our lakes, streams and groundwater.

This **management plan** will identify the operation and maintenance activities necessary to ensure long-term performance of your septic system. Some of these activities must be performed by you, the homeowner. Other tasks must be performed by a licensed septic maintainer or service provider. However, it is **YOUR** responsibility to make sure all tasks get accomplished in a timely manner.

The University of Minnesota's *Septic System Owner's Guide* contains additional tips and recommendations designed to extend the effective life of your system and save you money over time.

Proper septic system design, installation, operation and maintenance means safe and clean water!

Property Owner	Patrick & Jane Jacobwith	Email	patrick.jacobwith@sunset
Property Address	49131 373rd Place Palisade MN 56469	Property ID	35-0-027512
System Designer	Septic Check	Contact Info	320-983-2447
System Installer		Contact Info	
Service Provider/Maintainer		Contact Info	
Permitting Authority	Aitkin County	Contact Info	218-927-7342
Permit #		Date Inspected	

Keep this Management Plan with your Septic System Owner's Guide. The Septic System Owner's Guide includes a folder to hold maintenance records including pumping, inspection and evaluation reports. Ask your septic professional to also:

- Attach permit information, designer drawings and as-built of your system, if they are available.
- Keep copies of all pumping records and other maintenance and repair invoices with this document.
- Review this document with your maintenance professional at each visit; discuss any changes in product use, activities, or water-use appliances.

For a copy of the *Septic System Owner's Guide*, visit www.bookstores.umn.edu and search for the word "septic" or call 800-322-8642.

For more information see <http://septic.umn.edu>



Your Septic System

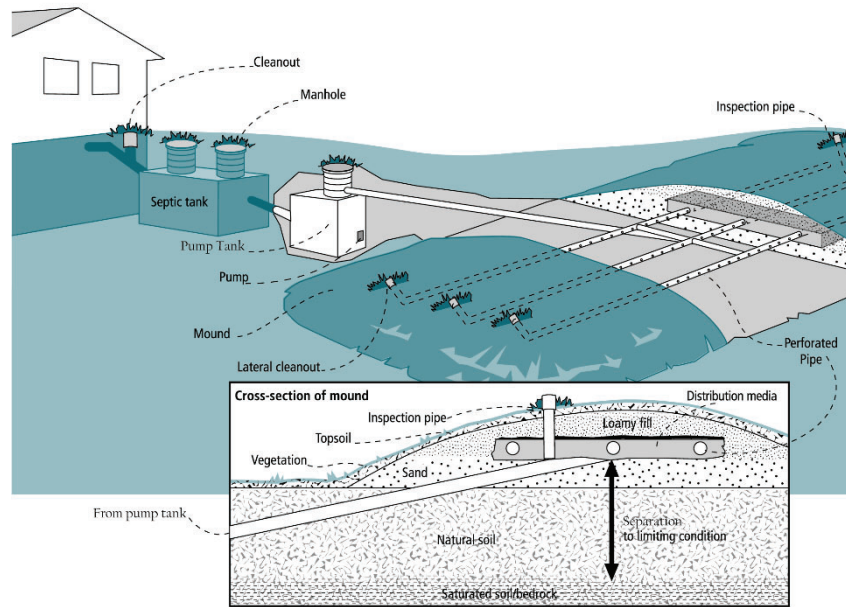

Septic System Specifics	
System Type: <input type="radio"/> I <input type="radio"/> II <input checked="" type="radio"/> III <input type="radio"/> IV* <input type="radio"/> V* (Based on MN Rules Chapter 7080.2200 – 2400) *Additional Management Plan required	<input checked="" type="checkbox"/> System is subject to operating permit* <input type="checkbox"/> System uses UV disinfection unit* Type of advanced treatment unit _____

Dwelling Type	Well Construction
Number of bedrooms: <u>4</u> but sized for 2 w time dose System capacity/ design flow (gpd): <u>300</u> Anticipated average daily flow (gpd): <u>300</u> Comments _____ Business? : <input type="radio"/> Y <input checked="" type="radio"/> N What type? _____	Well depth (ft): _____ <input checked="" type="checkbox"/> Cased well Casing depth: _____ <input type="checkbox"/> Other (specify): _____ Distance from septic (ft): <u>>50'</u> Is the well on the design drawing? <input checked="" type="radio"/> Y <input type="radio"/> N

Septic Tank	
<input type="checkbox"/> First tank Tank volume: <u>1250</u> gallons Does tank have two compartments? <input checked="" type="radio"/> Y <input type="radio"/> N <input type="checkbox"/> Second tank Tank volume: <u>540</u> gallons <input type="checkbox"/> Tank is constructed of <u>Plastic</u> <input type="checkbox"/> Effluent screen: <input type="radio"/> Y <input checked="" type="radio"/> N Alarm <input type="radio"/> Y <input checked="" type="radio"/> N	<input type="checkbox"/> Pump Tank <u>1060</u> gallons <input type="checkbox"/> Effluent Pump make/model: <u>Goulds PE 31</u> Pump capacity <u>18</u> GPM TDH <u>15.7</u> Feet of head <input type="checkbox"/> Alarm location <u>Outdoor Powerpost</u>

Soil Treatment Area (STA)	
Mound/At-Grade area (width x length): <u>34.4</u> ft x <u>49.4</u> ft Rock bed size (width x length): <u>10</u> ft x <u>25</u> ft Location of additional STA: _____ Type of distribution media: <u>1 1/2" Washed Rock</u>	<input checked="" type="checkbox"/> Inspection ports <input checked="" type="checkbox"/> Cleanouts <input type="checkbox"/> Surface water diversions <input type="checkbox"/> Additional STA not available



Homeowner Management Tasks

These *operation and maintenance* activities are your responsibility. *Chart on page 6 can help track your activities.*

Your toilet is not a garbage can. Do not flush anything besides human waste and toilet paper. No wet wipes, cigarette butts, disposal diapers, used medicine, feminine products or other trash!

The system and septic tanks needs to be
checked every 36 months

Your service provider or pumper/maintainer should evaluate if your tank needs to be pumped more or less often.

Seasonally or several times per year

- *Leaks.* Check (listen, look) for leaks in toilets and dripping faucets. Repair leaks promptly.
- *Soil treatment area.* Regularly check for wet or spongy soil around your soil treatment area. If surfaced sewage or strong odors are not corrected by pumping the tank or fixing broken caps and leaks, call your service professional. *Untreated sewage may make humans and animals sick.* Keep bikes, snowmobiles and other traffic off and control borrowing animals.
- *Alarms.* Alarms signal when there is a problem; contact your service professional any time the alarm signals.
- *Lint filter.* If you have a lint filter, check for lint buildup and clean when necessary. If you do not have one, consider adding one after washing machine.
- *Effluent screen.* If you do not have one, consider having one installed the next time the tank is cleaned along with an alarm.

Annually

- *Water usage rate.* A water meter or another device can be used to monitor your average daily water use. Compare your water usage rate to the design flow of your system (listed on the next page). Contact your septic professional if your average daily flow over the course of a month exceeds 70% of the design flow for your system.
- *Caps.* Make sure that all caps and lids are intact and in place. Inspect for damaged caps at least every fall. Fix or replace damaged caps before winter to help prevent freezing issues.
- *Water conditioning devices.* See Page 5 for a list of devices. When possible, program the recharge frequency based on *water demand (gallons)* rather than *time (days)*. Recharging too frequently may negatively impact your septic system. Consider updating to demand operation if your system currently uses time,
- *Review your water usage rate.* Review the Water Use Appliance chart on Page 5. Discuss any major changes with your service provider or pumper/maintainer.

During each visit by a service provider or pumper/maintainer

- Make sure that your service professional services the tank through the manhole. (NOT through a 4" or 6" diameter inspection port.)
- Ask how full your tank was with sludge and scum to determine if your service interval is appropriate.
- Ask your pumper/maintainer to accomplish the tasks listed on the Professional Tasks on Page 4.



Professional Management Tasks

These are the operation and maintenance activities that a pumper/maintainer performs to help ensure long-term performance of your system. At each visit a written report/record must be provided to homeowner.

Plumbing/Source of Wastewater

- Review the Water Use Appliance Chart on Page 5 with homeowner. Discuss any changes in water use and the impact those changes may have on the septic system.
- Review water usage rates (if available) with homeowner.

Septic Tank/Pump Tanks

- *Manhole lid.* A riser is recommended if the lid is not accessible from the ground surface. Insulate the riser cover for frost protection.
- *Liquid level.* Check to make sure the tank is not leaking. The liquid level should be level with the bottom of the outlet pipe. (If the water level is below the bottom of the outlet pipe, the tank may not be watertight. If the water level is higher than the bottom of the outlet pipe of the tank, the effluent screen may need cleaning, or there may be ponding in the soil treatment area.)
- *Inspection pipes.* Replace damaged or missing pipes and caps.
- *Baffles.* Check to make sure they are in place and attached, and that inlet/outlet baffles are clear of buildup or obstructions.
- *Effluent screen.* Check to make sure it is in place; clean per manufacturer recommendation. Recommend retrofitted installation if one is not present.
- *Alarm.* Verify that the alarm works.
- *Scum and sludge.* Measure scum and sludge in each compartment of each septic and pump tank, pump if needed.

Pump

- *Pump and controls.* Check to make sure the pump and controls are operating correctly.
- *Pump vault.* Check to make sure it is in place; clean per manufacturer recommendations.
- *Alarm.* Verify that the alarm works.
- *Drainback.* Check to make sure it is draining properly.
- *Event counter or elapsed time meter.* Check to see if there is an event counter or elapsed time meter for the pump. If there is one or both, calculate the water usage rate and compare to the anticipated use listed on Design and Page 2. Dose Volume: _____ gallons: Pump run time: _____ Minutes

Soil Treatment Area

- *Inspection pipes.* Check to make sure they are properly capped. Replace caps and pipes that are damaged.
- *Surfacing of effluent.* Check for surfacing effluent or other signs of problems.
- *Lateral flushing.* Check lateral distribution; if cleanouts exist, flush and clean at recommended frequency.
- *Vegetation* - Check to see that a good growth of vegetation is covering the system.

All other components – evaluate as listed here: _____



**Water-Use Appliances and
Equipment in the Home**

Appliance	Impacts on System	Management Tips
Garbage disposal	<ul style="list-style-type: none"> • Uses additional water. • Adds solids to the tank. • Finely-ground solids may not settle. Unsettled solids can exit the tank and enter the soil treatment area. 	<ul style="list-style-type: none"> • Use of a garbage disposal is not recommended. • Minimize garbage disposal use. Compost instead. • To prevent solids from exiting the tank, have your tank pumped more frequently. • Add an effluent screen to your tank.
Washing machine	<ul style="list-style-type: none"> • Washing several loads on one day uses a lot of water and may overload your system. • Overloading your system may prevent solids from settling out in the tank. Unsettled solids can exit the tank and enter the soil treatment area. 	<ul style="list-style-type: none"> • Choose a front-loader or water-saving top-loader, these units use less water than older models. • Limit the addition of extra solids to your tank by using liquid or easily biodegradable detergents. Limit use of bleach-based detergents and fabric softeners. • Install a lint filter after the washer and an effluent screen to your tank • Wash only full loads and think even – spread your laundry loads throughout the week.
Dishwasher	<ul style="list-style-type: none"> • Powdered and/or high-phosphorus detergents can negatively impact the performance of your tank and soil treatment area. • New models promote “no scraping”. They have a garbage disposal inside. 	<ul style="list-style-type: none"> • Use gel detergents. Powdered detergents may add solids to the tank. • Use detergents that are low or no-phosphorus. • Wash only full loads. • Scrape your dishes anyways to keep undigested solids out of your septic system.
Grinder pump (in home)	<ul style="list-style-type: none"> • Finely-ground solids may not settle. Unsettled solids can exit the tank and enter the soil treatment area. 	<ul style="list-style-type: none"> • Expand septic tank capacity by a factor of 1.5. • Include pump monitoring in your maintenance schedule to ensure that it is working properly. • Add an effluent screen.
Large bathtub (whirlpool)	<ul style="list-style-type: none"> • Large volume of water may overload your system. • Heavy use of bath oils and soaps can impact biological activity in your tank and soil treatment area. 	<ul style="list-style-type: none"> • Avoid using other water-use appliances at the same time. For example, don’t wash clothes and take a bath at the same time. • Use oils, soaps, and cleaners in the bath or shower sparingly.
Clean Water Uses	Impacts on System	Management Tips
High-efficiency furnace	<ul style="list-style-type: none"> • Drip may result in frozen pipes during cold weather. 	<ul style="list-style-type: none"> • Re-route water directly out of the house. Do not route furnace discharge to your septic system.
Water softener Iron filter Reverse osmosis	<ul style="list-style-type: none"> • Salt in recharge water may affect system performance. • Recharge water may hydraulically overload the system. 	<ul style="list-style-type: none"> • These sources produce water that is not sewage and should not go into your septic system. • Reroute water from these sources to another outlet, such as a dry well, draitile or old drainfield.
Surface drainage Footing drains	<ul style="list-style-type: none"> • Water from these sources will overload the system and is prohibited from entering septic system. 	<ul style="list-style-type: none"> • When replacing, consider using a demand-based recharge vs. a time-based recharge. • Check valves to ensure proper operation; have unit serviced per manufacturer directions



Homeowner Maintenance Log

Track maintenance activities here for easy reference. See list of management tasks on pages 3 and 4.

Activity	Date accomplished									
Check frequently:										
Leaks: check for plumbing leaks*										
Soil treatment area check for surfacing**										
Lint filter: check, clean if needed*										
Effluent screen (if owner-maintained)***										
Alarm**										
Check annually:										
Water usage rate (maximum gpd <u>300</u>)										
Caps: inspect, replace if needed										
Water use appliances – review use										
Other:										

*Monthly

**Quarterly

***Bi-Annually

Notes: If flow exceeds system capacity, check for and repair any leaks into the system, including household plumbing fixtures. If system ponds or otherwise cannot handle flow, repair options include; add time dosing, adding pre-treatment, or expanding the system.

"As the owner of this SSTS, I understand it is my responsibility to properly operate and maintain the sewage treatment system on this property, utilizing the Management Plan. If requirements in this Management Plan are not met, I will promptly notify the permitting authority and take necessary corrective actions. If I have a new system, I agree to adequately protect the reserve area for future use as a soil treatment system."

Property Owner Signature:

Date

Management Plan Prepared By: **Melissa Besser**

Certification # **691**

Permitting Authority: **Aitkin County**



The Infiltrator IM-540 is a lightweight strong and durable septic/pump tank. This watertight tank design is offered with Infiltrator's line of custom-fit risers and heavy-duty lids. Infiltrator injection molded tanks provide a revolutionary improvement in plastic tank design, offering long-term exceptional strength and watertightness.

Features & Benefits

- Strong injection molded polypropylene construction
- Lightweight plastic construction and inboard lifting lugs allow for easy delivery and handling
- Integral heavy-duty green lids that interconnect with TW™ risers and pipe riser solutions
- Structurally reinforced access ports eliminate distortion during installation and pump-outs
- Reinforced structural ribbing offers additional strength
- Can be installed with 6" to 48" of cover
- Can be pumped dry during pump-outs
- Suitable for use as a pump tank or rainwater (non-potable) tank
- No special installation, backfill or water filling procedures are required
- No special water filling requirements are necessary
- The tank may be backfilled with suitable native soil. See installation instructions for guidance.

TANK CUTAWAY

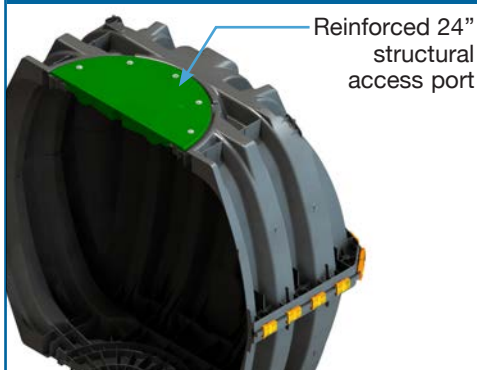

MID-SEAM CUTAWAY

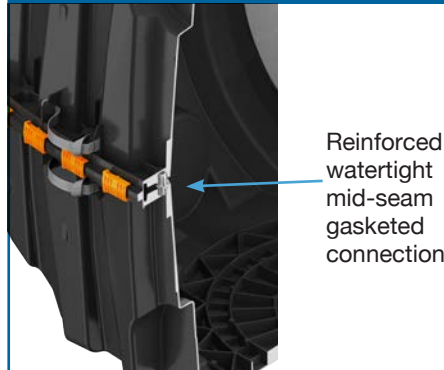

RISER CUTAWAY

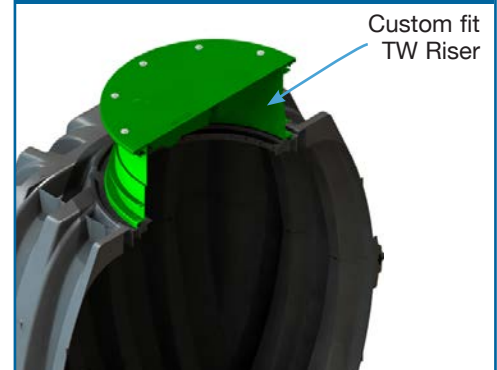

IM-540 General Specifications and Illustrations

The IM-540 is an injection molded two piece mid-seam plastic tank. The IM-540 injection molded plastic design allows for a mid-seam joint that has precise dimensions for accepting an engineered EPDM gasket. Infiltrator's gasket design utilizes technology from the water industry to deliver proven means of maintaining a watertight seal. The two-piece design is permanently fastened using a series of non-corrosive plastic alignment dowels and locking seam clips. The IM-540 is assembled and sold through a network of certified Infiltrator distributors.

Must be backfilled and installed in accordance with Infiltrator Water Technologies, Infiltrator IM-Series Septic Tank General Installation Instructions and for shallow ground water conditions reference the Infiltrator IM-Series Tank Buoyancy Control Guidance.

Please visit www.infiltratorwater.com/images/pdf/ManualsGuides/TANK01.pdf for the latest information.

IM-540	
Total Capacity	552 gal (2090 L)
Length	64.9" (1648 mm)
Width	61.7" (1567 mm)
Height	54.6" (1387 mm)
Maximum Burial Depth	48" (1219 mm)
Minimum Burial Depth	6" (152 mm)
Maximum Pipe Diameter	4" (100 mm)
Weight	169 lbs (77 kg)

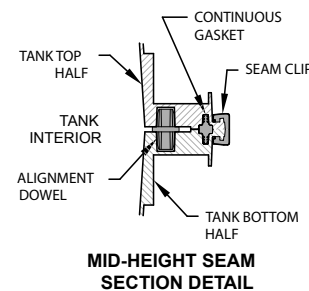
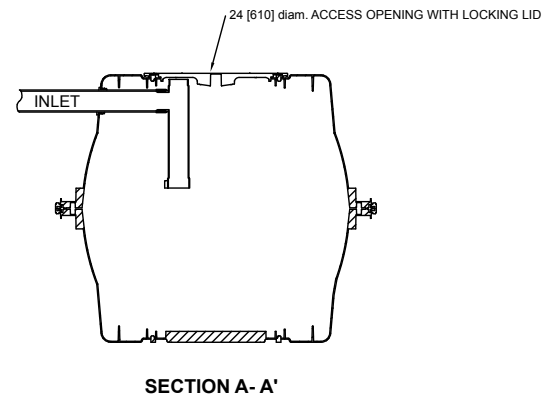
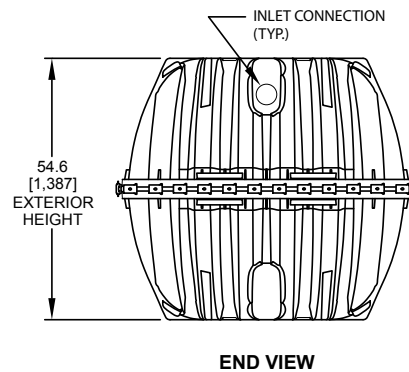
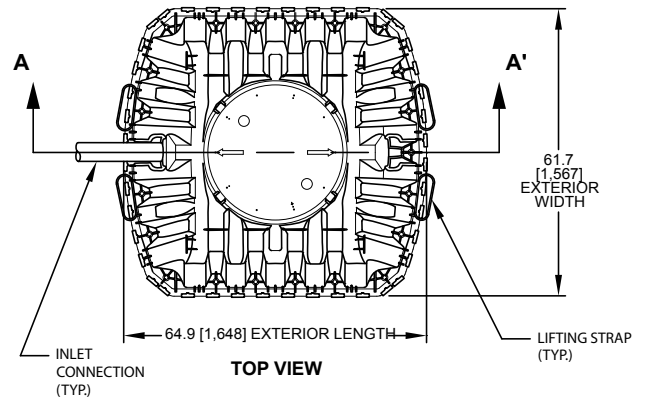

4 Business Park Road
 P.O. Box 768
 Old Saybrook, CT 06475
 860-577-7000 • Fax 860-577-7001
1-800-221-4436
www.infiltratorwater.com

U.S. Patents: 4,759,661; 5,017,041; 5,156,488; 5,336,017; 5,401,116; 5,401,459; 5,511,903; 5,716,163; 5,588,778; 5,839,844 Canadian Patents: 1,329,959; 2,004,564 Other patents pending. Infiltrator, Equalizer, Quick4, and SideWinder are registered trademarks of Infiltrator Water Technologies. Infiltrator is a registered trademark in France. Infiltrator Water Technologies is a registered trademark in Mexico. Contour, MicroLeaching, PolyTuff, ChamberSpacer, MultiPort, PosiLock, QuickCut, QuickPlay, SnapLock and StraightLock are trademarks of Infiltrator Water Technologies. PolyLok is a trademark of PolyLok, Inc. TUF-TITE is a registered trademark of TUF-TITE, INC. Ultra-Rib is a trademark of IPEX Inc.

© 2013 Infiltrator Water Technologies, LLC. All rights reserved. Printed in U.S.A.

IM11 1116

Contact Infiltrator Water Technologies' Technical Services Department for assistance at 1-800-221-4436



Features & Benefits

- Strong injection molded polypropylene construction
- Lightweight plastic construction and inboard lifting lugs allow for easy delivery and handling
- Integral heavy-duty green lids that interconnect with TW™ risers and pipe riser solutions
- Structurally reinforced access ports eliminate distortion during installation and pump-outs
- Reinforced structural ribbing and fiberglass bulkheads offer additional strength
- Can be installed with 6" to 48" of cover
- Can be pumped dry during pump-outs
- Suitable for use as a septic tank, pump tank, or rainwater (non-potable) tank
- No special water filling requirements are necessary
- The tank may be backfilled with suitable native soil. See installation instructions for guidance.

The Infiltrator IM-1060 is a lightweight strong and durable septic tank. This watertight tank design is offered with Infiltrator's line of custom-fit risers and heavy-duty lids. Infiltrator injection molded tanks provide a revolutionary improvement in plastic septic tank design, offering long-term exceptional strength and watertightness.

TANK CUTAWAY

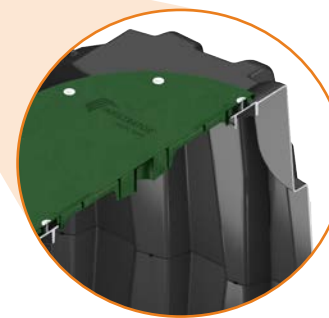
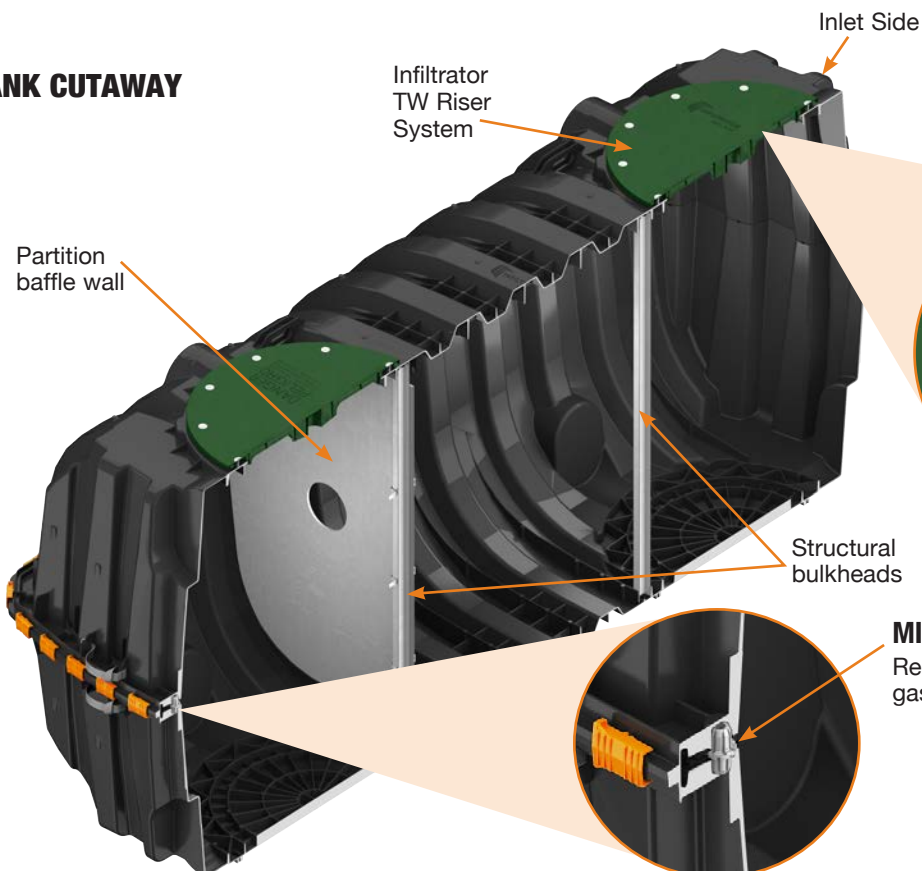

HEAVY DUTY LID CUTAWAY

Reinforced 24" structural access port

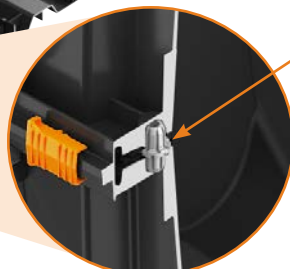

MID-SEAM CUTAWAY

Reinforced water tight mid-seam gasketed connection

IM-1060 General Specifications and Illustrations

The IM-1060 is an injection molded two piece mid-seam plastic tank. The IM-1060 injection molded plastic design allows for a mid-seam joint that has precise dimensions for accepting an engineered EPDM gasket. Infiltrator's gasket design utilizes technology from the water industry to deliver proven means of maintaining a watertight seal. The two-piece design is permanently fastened using a series of non-corrosive plastic alignment dowels and locking seam clips. The IM-1060 is assembled and sold through a network of certified Infiltrator distributors.

Must be backfilled and installed in accordance with Infiltrator Water Technologies, Infiltrator IM-Series Septic Tank General Installation Instructions and for shallow ground water conditions reference the Infiltrator IM-Series Tank Buoyancy Control Guidance.

Please visit www.infiltratorwater.com/images/pdf/ManualsGuides/TANK01.pdf for the latest information.

IM-1060	
Working Capacity	1094 gal (4141 L)
Total Capacity	1287 gal (4872 L)
Airspace	16.5%
Length	127" (3226 mm)
Width	62.2" (1580 mm)
Length-to-Width Ratio	2.3 to 1
Height	54.7" (1389 mm)
Liquid Level	44" (1118 mm)
Invert Drop	3" (76 mm)
Fiberglass Supports	2
Compartments	1 or 2
Maximum Burial Depth	48" (1219 mm)
Minimum Burial Depth	6" (152 mm)
Maximum Pipe Diameter	6" (152 mm)
Weight	320 lbs (145 kg)

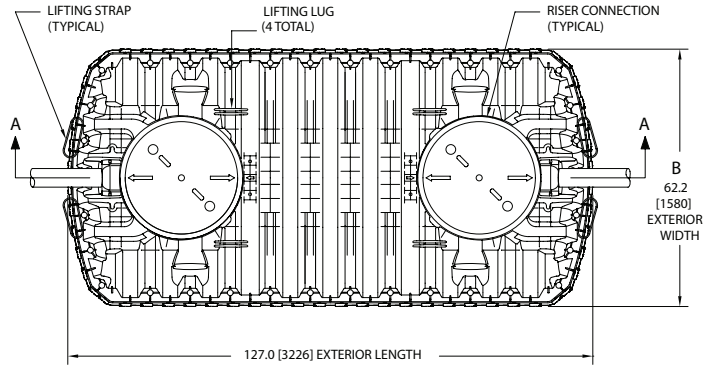

TOP VIEW

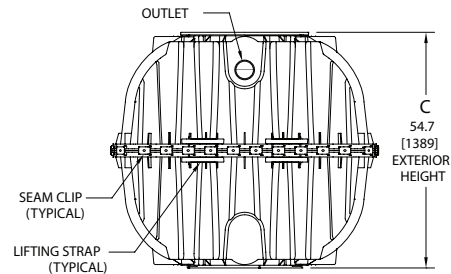

END VIEW

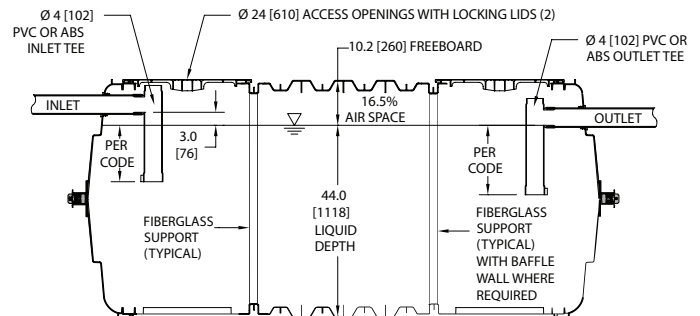

SIDE VIEW

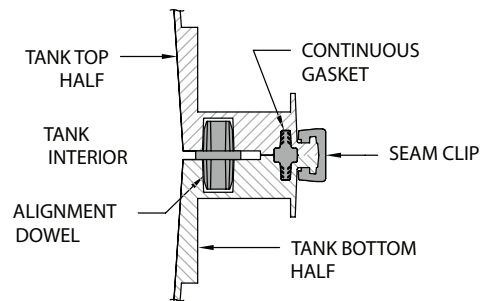

MID-HEIGHT SEAM SECTION



4 Business Park Road
P.O. Box 768
Old Saybrook, CT 06475
860-577-7000 • Fax 860-577-7001
1-800-221-4436
www.infiltratorwater.com

U.S. Patents: 4,759,661; 5,017,041; 5,156,488; 5,336,017; 5,401,116; 5,401,459; 5,511,903; 5,716,163; 5,588,778; 5,839,844 Canadian Patents: 1,329,959; 2,004,564 Other patents pending. Infiltrator, Equalizer, Quick4, and SideWinder are registered trademarks of Infiltrator Water Technologies. Infiltrator is a registered trademark in France. Infiltrator Water Technologies is a registered trademark in Mexico. Contour, MicroLeaching, PolyTuff, ChamberSpacer, MultiPort, PosiLock, QuickCut, QuickPlay, SnapLock and StraightLock are trademarks of Infiltrator Water Technologies. PolyLok is a trademark of PolyLok, Inc. TUF-TITE is a registered trademark of TUF-TITE, INC. Ultra-Rib is a trademark of IPEX Inc.

© 2016 Infiltrator Water Technologies, LLC. All rights reserved. Printed in U.S.A.

IM02 1116

Contact Infiltrator Water Technologies' Technical Services Department for assistance at 1-800-221-4436

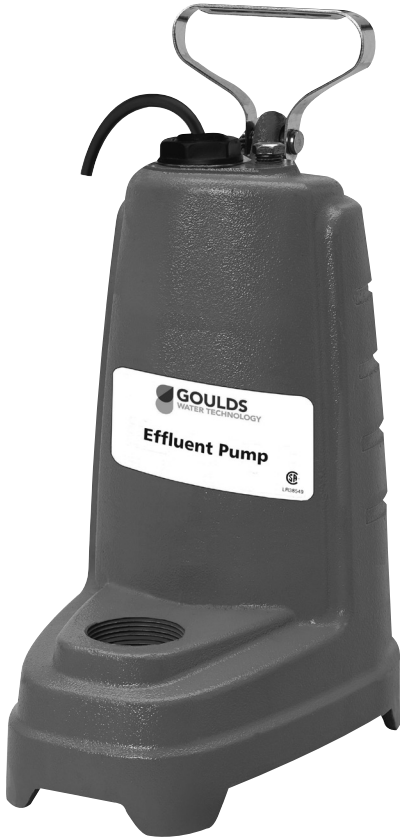

FEATURES

- Corrosion resistant construction
- Cast iron body
- Thermoplastic impeller and cover.
- Upper sleeve and lower heavy duty ball bearing construction.
- Motor is permanently lubricated for extended service life.
- Powered for continuous operation.
- All ratings are within the working limits of the motor.
- Quick disconnect power cord, 20' standard length, heavy duty 16/3 SJTW with 115 or 230 volt grounding plug.
- Complete unit is heavy duty, portable and compact.
- Mechanical seal is carbon, ceramic, BUNA and stainless steel.
- Stainless steel fasteners

PE

SUBMERSIBLE EFFLUENT PUMP



APPLICATIONS

Specially designed for the following uses:

- Mound Systems
- Effluent/Dosing Systems
- Low Pressure Pipe Systems
- Basement Draining
- Heavy Duty Sump/Dewatering

SPECIFICATIONS

Pump - General:

- Discharge: 1½" NPT
- Temperature: 104°F (40°C) maximum, continuous when fully submerged.
- Solids handling: ½" maximum sphere.
- Automatic models include a float switch.
- Manual models available.
- Pumping range: see performance chart or curve.

PE31 Pump:

- Maximum capacity: 53 GPM
- Maximum head: 25' TDH

PE41 Pump:

- Maximum capacity: 61 GPM
- Maximum head: 29' TDH

PE51 Pump:

- Maximum capacity: 70 GPM
- Maximum head: 37' TDH

MOTOR

General:

- Single phase
- 60 Hertz
- 115 and 230 volts
- Built-in thermal overload protection with automatic reset.
- Class B insulation
- Oil-filled design
- High strength carbon steel shaft

PE31 Motor:

- .33 HP, 3000 RPM
- 115 volts
- Shaded pole design

PE41 Motor:

- .40 HP, 3400 RPM
- 115 and 230 volts
- PSC design

PE51 Motor:

- .50 HP, 3400 RPM
- 115 and 230 volts
- PSC design

AGENCY LISTINGS



Tested to UL 778 and CSA 22.2 108 Standards
By Canadian Standards Association
File #LR38549

PUMP INFORMATION

Order No.	HP	Volts	Amps	Minimum Circuit Breaker	Phase	Float Switch Style	Cord Length	Discharge Connection	Minimum Basin Diameter	Maximum Solids Size	Shipping Weight lbs/kg
PE31M	0.33	115	12	20	1	Manual / No Switch	20'	1.5"	18"	.5"	31 / 14.1
PE31P1						Piggyback Float Switch					
PE41M	0.4	230	7.5	15		Manual / No Switch					
PE41P1				Piggyback Float Switch							
PE42M	0.4	230	3.7	10		Manual / No Switch					
PE42P1				Piggyback Float Switch							
PE51M	0.5	115	9.5	20		Manual / No Switch					
PE51P1						Piggyback Float Switch					
PE52M		230	4.7	10		Manual / No Switch					
PE52P1						Piggyback Float Switch					

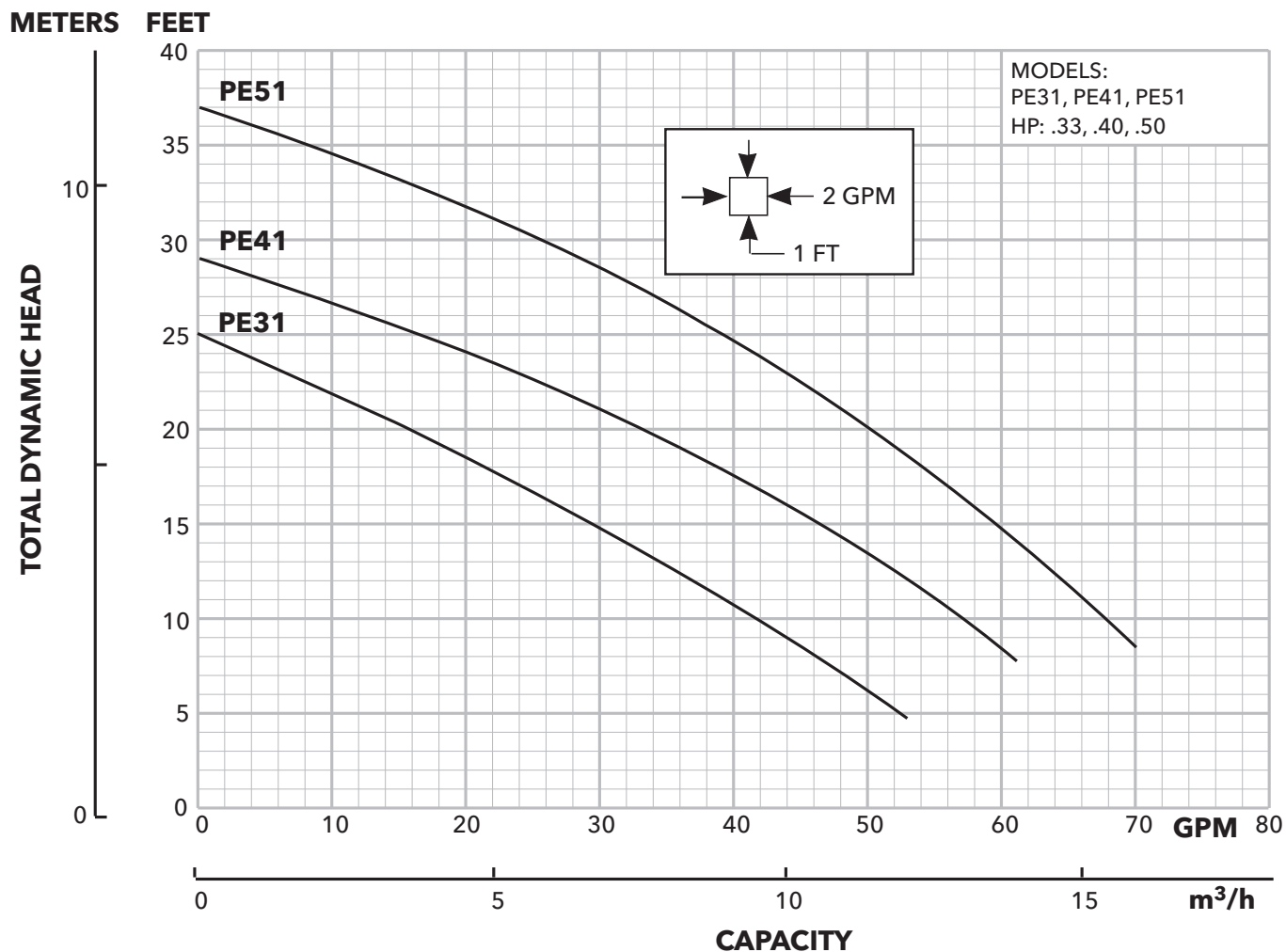

PERFORMANCE RATINGS

PE31

Total Head (feet of water)	GPM
5	52
10	42
15	29
20	16
25	0

PE41

Total Head (feet of water)	GPM
8	61
10	57
15	46
20	33
25	16

PE51

Total Head (feet of water)	GPM
10	67
15	59
20	50
25	39
30	26
35	8

DIMENSIONS

(All dimensions are in inches. Do not use for construction purposes.)

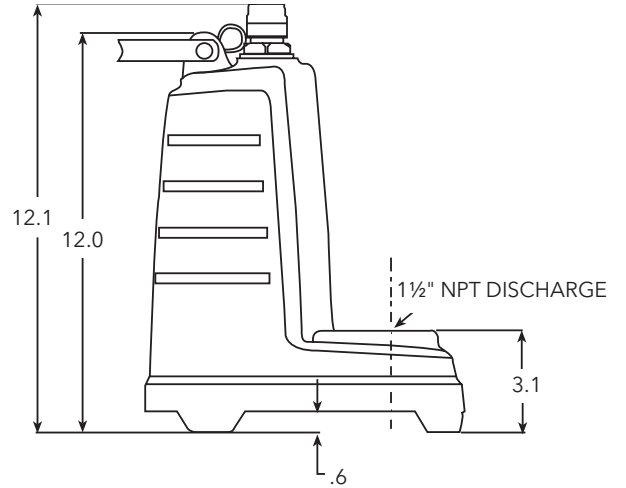
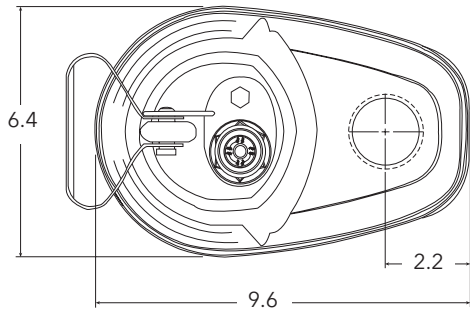

xylem
Let's Solve Water

Xylem Inc.
2881 East Bayard Street Ext., Suite A
Seneca Falls, NY 13148
Phone: (866) 325-4210
Fax: (888) 322-5877
www.gouldswatertechnology.com

Goulds is a registered trademark of Goulds Pumps, Inc. and is used under license.
© 2016 Xylem Inc. BPE R1 September 2016

INSTALLER FRIENDLY SERIES®

Advanced Single Phase Simplex or Duplex Control Panels

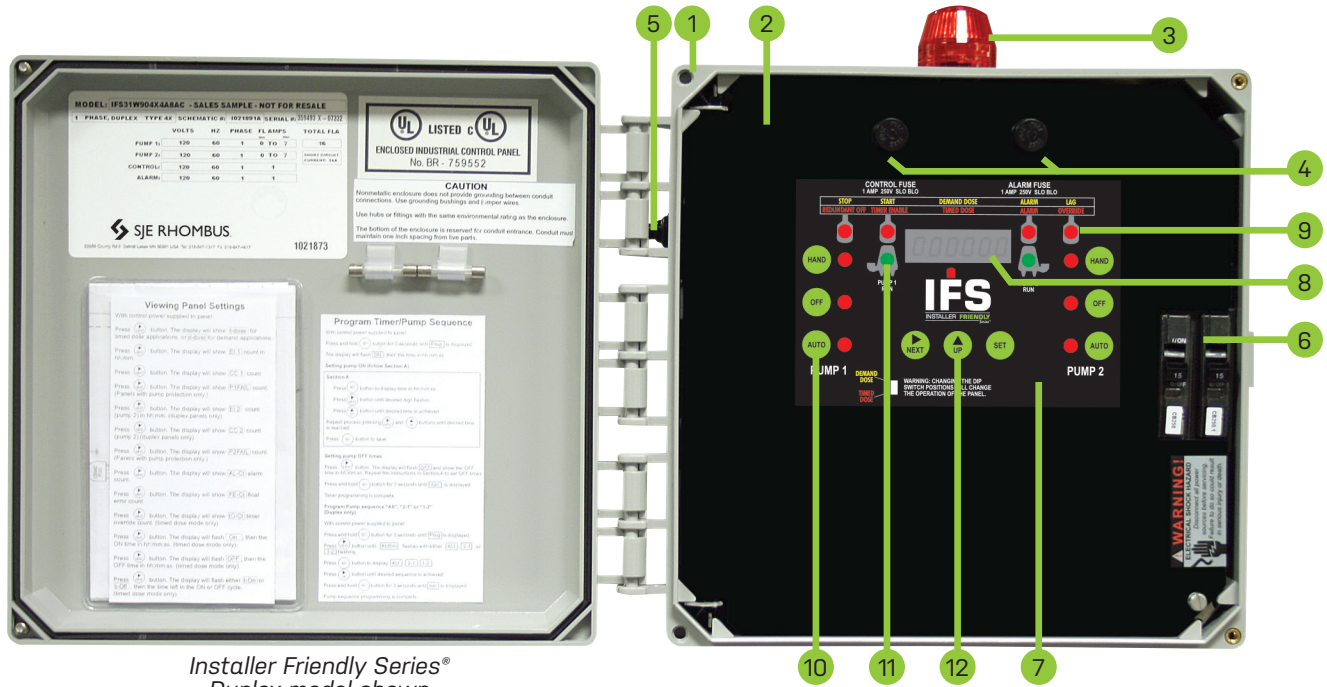

Installer Friendly Series®
Duplex model shown



The IFS control panels utilize an innovative circuit board design to control one or two 120/208/240V pump(s) in on-site wastewater applications. IFS panels feature an easy-to-use touch pad on inner door for programming and system monitoring: level status indicators, HOA buttons, pump run indicator(s) and menu buttons. Includes digital LED display for mode (TD), pump elapsed time, events (cycles), alarm counts, float error counts and more!

Each panel can be easily converted to either demand dose to timed dose in the field. Float-based or C-Level™ floatless sensor options available. IFS panels are also available for three phase, capacitor start/run and drip irrigation applications.

PART NO. MODEL NUMBER

- **1022726** FS21W114H8AC17G (Simplex)
- **1022727** FS41W114H8AC17G (Duplex)

COMPONENTS

1. NEMA 4X enclosure for indoor/outdoor use
2. Inner door for added safety
3. Red alarm beacon
4. Separate alarm and control power and fuses
5. Test/Normal/Silence switch
6. Circuit breakers provide pump disconnect and branch circuit protection
7. Easy to use touch pad for programming pump control
8. Digital LED display
9. Float status indicators
10. Hand/Off/Auto buttons with indicators to control pump mode
11. Pump run indicators
12. Menu navigation buttons



INSTALLER FRIENDLY SERIES® - IFS Single Phase Simplex

Single phase, simplex demand dose or timed dose, float or C-Level™ controlled system for pump control and system monitoring.

The IFS simplex control panel is designed to control one 120, 208, 240 VAC single phase pump in water and sewage installations. The panel features an easy-to-use touch pad with display on the inner door for programming and system monitoring. The panel configuration can be easily converted in the field to either a timed dose or demand dose.

The optional C-Level™ sensor is a pressure transducer that senses the liquid level in the tank and sends a signal to the IFS panel. Pump activation levels can be adjusted by using the panel touch pad. C-Level™ CL40 sensor operating range is 3-39.9 inches (7.6-101.3 cm). C-Level™ CL100 operating range is 3-99.5 inches (7.6-252.7 cm).

TOUCH PAD FEATURES

- A. Level Status Indicators** illuminate when floats or set points are activated. Alarm will activate if a float operates out of sequence.
- B. HOA (Hand-Off-Automatic) Buttons** control pump mode with indication. Hand mode defaults to Automatic when stop level or redundant off level is reached.
- C. Pump Run Indicator** illuminates when pump is called to run.
- D. LED Display** shows system information including: level in inches or centimeters (C-Level™ only), mode, pump elapsed time (hh:mm), events (cycles), alarm counter, float error count, timed dose override counter (timed dose only), and ON/OFF times (timed dose only).
- E. NEXT Push Button** toggles display.
- F. UP and SET Push Buttons** set pump ON/OFF times (timed dose only) or activation levels (C-Level™ only).

PANEL COMPONENTS

- 1. Enclosure** measures 12x10x6 inches (30.48x24.4x15.24) NEMA 4X (ultraviolet stabilized thermoplastic, padlockable with integral mounting flanges, drip shield, (2) heavy duty cover latches, and stainless steel ¼ turn set screw; for outdoor or indoor use). Note: added options, voltage, and amp range selected may change enclosure size and enclosure features, and component layout.
- 2. Red Alarm Beacon** provides 360° visual check of alarm condition.
- 3. Exterior Alarm Test/Normal/Silence Switch** allows horn and light to be tested and horn to be silenced in an alarm condition. Alarm automatically resets once alarm condition is cleared.
- 4. Alarm Horn** provides audio warning of alarm condition (83 to 85 decibel rating).
- 5. Circuit Breaker** (optional) provides pump disconnect and branch circuit protection.
- 6. Power Relay** controls pump by switching electrical lines. Definite purpose contactor used when pump full load amps are above 15.
- 7. Float Connection Terminal Block**
- 8. Incoming Control/Alarm Power & Pump Terminal Block**
- 9. Control Power Indicator/Fuse** indicator light illuminates if control power is present in panel. Alarm will activate if control fuse is blown.
- 10. Alarm Power Indicator/Fuse** indicator light illuminates if alarm power is present in panel.
- 11. Ground Lug**

NOTE: Schematic/Wiring Diagram and Pump Specification Label are located inside the panel on enclosure cover.

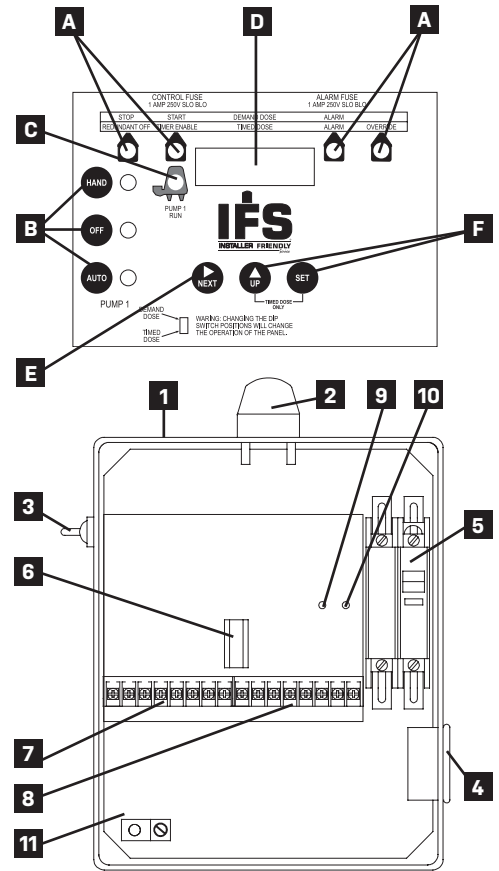

Model Shown IFS11W114X8AC

Reg. Cdn Pat. & TM Off

C-Level™ Sensor US Patent No. 8,336,385; 8,567,242; 8,650,949

FEATURES

- Entire control system is UL Listed to meet and/or exceed industry safety standards
- Dual safety certification for the United States and Canada
- Standard package includes:
 - Demand Dose** - three 20' control switches
 - Timed Dose** - two 20' control switches
- Available with EZconnex® float system
- Complete with step-by-step installation instructions
- Five-year limited warranty
- One-year limited warranty on C-Level™ Sensor



SJE RHOMBUS

1-888-DIAL-SJE • 1-218-847-1317

1-218-847-4617 Fax

email: customer.service@sjeinc.com

www.sjerhombus.com

B.11

California Prop 65 requires the following: WARNING Cancer and Reproductive Harm - www.P65Warnings.ca.gov

SEE REVERSE SIDE FOR ORDERING INFORMATION.

SEE PRICE BOOK FOR LIST PRICE.

IFS**1****W****8AC10E****MODEL IFS****MODEL TYPE**

- 1 = SPLX TIMED DOSE (includes option 8AC standard)
 2 = SPLX DEMAND DOSE (includes option 8AC standard)

ALARM PACKAGE

- 1 = alarm package (includes test/normal/silence switch, fuse, red light & horn)

ENCLOSURE RATING

- W = NEMA 4X

STARTING DEVICE

- 1 = 120/208/240 VAC
 9 = 120 VAC

PUMP FULL LOAD AMPS

- 0 = 0-7 FLA
 1 = 7-15 FLA
 2 = 15-20 FLA

PUMP DISCONNECTS

- 0 = no pump disconnect
 4 = circuit breaker
 120 VAC (must select starting device option 9)
 120/208/240 VAC (must select starting device option 1)

SWITCH APPLICATIONS

- H = floats (Timed dose = timer enable and alarm / Demand dose = stop, start, and alarm) (select 17 option)
 E = EZconnex® float switch system (select 33, 35 or 36 option)
 timed dose
 demand dose
 X = no floats
 timed dose
 demand dose
 C = C-Level™ sensor (must select 24 or 29 option)
 (select option 3E and/or 4A & 4D for high water alarm and/or redundant off floats)
 timed dose
 demand dose

Note: Pump down applications only.

Industry practices suggest that a secondary device, such as a float switch, be used for redundant activation of the high level alarm and pump shut off.

OPTIONS *Listed below*

- | CODE | DESCRIPTION |
|-------------------------------------|--|
| <input type="checkbox"/> | 1J Duo alarm inputs |
| <input type="checkbox"/> | 3A Alarm flasher |
| <input type="checkbox"/> | 3B Manual alarm reset |
| <input type="checkbox"/> | 3E High water alarm float (must select 17 option)
(Available only when Switch Applications = C) |
| <input type="checkbox"/> | 4A Redundant off (select option 4D if floats are required)
Demand Dose
Timed Dose |
| <input type="checkbox"/> | 4D Redundant off float
(must select 4A option) (must select 17 option) |
| <input type="checkbox"/> | 6A Auxiliary alarm contacts, Form C |
| <input checked="" type="checkbox"/> | 8AC Display board includes: ETM counter, events (cycles)
counter, alarm counter, and override counter (timed dose
only). (Included as standard.) |
| <input checked="" type="checkbox"/> | 10E Lockable latch - NEMA 4X (Included as standard.) |
| <input type="checkbox"/> | 10F Lightning arrester (must select pump circuit breaker,
control and alarm power combined) |
| <input type="checkbox"/> | 10K Anti-condensation heater |
| <input type="checkbox"/> | 11C NEMA 1 alarm panel (must select option 6A) |
| <input type="checkbox"/> | 11D NEMA 4X alarm panel
(must select option 6A) |
| <input type="checkbox"/> | 15A Control / Alarm circuit breaker |
| <input type="checkbox"/> | 16A 10' cord in lieu of 20' (per float) |
| <input type="checkbox"/> | 16B 15' cord in lieu of 20' (per float) |
| <input type="checkbox"/> | 16C 30' cord in lieu of 20' (per float) |
| <input type="checkbox"/> | 16D 40' cord in lieu of 20' (per float) |

- | CODE | DESCRIPTION |
|--------------------------|---|
| <input type="checkbox"/> | 17C Sensor Float* / internally weighted ▲ (per float) |
| <input type="checkbox"/> | 17D Sensor Float* / externally weighted ▲ (per float) |
| <input type="checkbox"/> | 17G MilliAmpMaster™/ pipe clamp ● (per float) |
| <input type="checkbox"/> | 17H MilliAmpMaster™/ externally weighted ● (per float) |
| <input type="checkbox"/> | 17J Sensor Float* / pipe clamp ▲ (per float) |
| <input type="checkbox"/> | 18A Timer override float
(timed dose float panel only) |
| <input type="checkbox"/> | 24E C-Level™ CL40 sensor with 4' vent tube & 20' cord |
| <input type="checkbox"/> | 24F C-Level™ CL40 sensor with 4' vent tube & 40' cord |
| <input type="checkbox"/> | 24G C-Level™ CL40 sensor with 8' vent tube & 20' cord |
| <input type="checkbox"/> | 24H C-Level™ CL40 sensor with 8' vent tube & 40' cord |
| <input type="checkbox"/> | 24X No C-Level™ CL40 sensor |
| <input type="checkbox"/> | 29A C-Level™ CL100 sensor w/10' vent tube & 20' cord |
| <input type="checkbox"/> | 29B C-Level™ CL100 sensor w/10' vent tube & 40' cord |
| <input type="checkbox"/> | 29X No C-Level™ CL100 sensor |
| <input type="checkbox"/> | 33D EZconnex® 3-Port, 25', w/10' floats (3) /pipe clamp * |
| <input type="checkbox"/> | 33E EZconnex® 3-Port, 50', w/10' floats (3) /pipe clamp * |
| <input type="checkbox"/> | 33G EZconnex® 3-Port, 25', w/20' floats (3) /pipe clamp * |
| <input type="checkbox"/> | 33H EZconnex® 3-Port, 50', w/20' floats (3) /pipe clamp * |
| <input type="checkbox"/> | 35D EZconnex® 4-Port, 25', w/10' floats (4) /pipe clamp * |
| <input type="checkbox"/> | 35E EZconnex® 4-Port, 50', w/10' floats (4) /pipe clamp * |
| <input type="checkbox"/> | 35G EZconnex® 4-Port, 25', w/20' floats (4) /pipe clamp * |
| <input type="checkbox"/> | 35H EZconnex® 4-Port, 50', w/20' floats (4) /pipe clamp * |
| <input type="checkbox"/> | 36D EZconnex® 3-Port, 25' w/10' floats (2) /pipe clamp,
sealing plug * |
| <input type="checkbox"/> | 36E EZconnex® 3-Port, 50' w/10' floats (2) /pipe clamp,
sealing plug * |
| <input type="checkbox"/> | 36G EZconnex® 3-Port, 25' w/20' floats (2) /pipe clamp,
sealing plug * |
| <input type="checkbox"/> | 36H EZconnex® 3-Port, 50' w/20' floats (2) /pipe clamp,
sealing plug * |

● Mechanically-activated ▲ Mercury-activated

* EZconnex® mechanically-activated, narrow angle float switches with quick release connections. © 2018 SJE, Inc. All Rights Reserved. SJE RHOMBUS is a trademark of SJE, Inc.

Installer Friendly Series®

SJE-Rhombus® Type IFS w/C-Level™ Sensor

Installation Instructions and Operation/Troubleshooting Manual

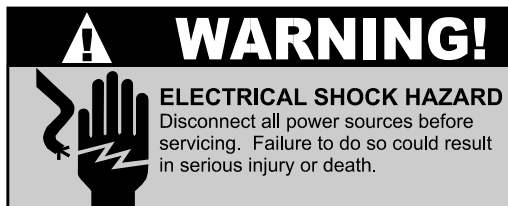

This control panel must be installed and serviced by a licensed electrician in accordance with the National Electric Code NFPA-70, state and local electrical codes. All conduit running from the sump or tank to the control panel must be sealed with conduit sealant to prevent moisture or gases from entering the panel. **NEMA 4X enclosures are for indoor or outdoor use**, primarily to provide a degree of protection against corrosion, windblown dust and rain, splashing water and hose-directed water. **Cable connectors must be liquid-tight in NEMA 4X enclosures.**

The C-Level sensor is suitable for use in sewage applications. **Do NOT use in potable water.**

Installation

Installer Friendly Series® (IFS) control panels are designed to control pump(s). The controller records number of pump cycles, elapsed run time, alarm counts, and signal error counts.

Mounting the Control Panel

Note: The control panel should not be mounted in a location that may be subject to submersion.

1. Determine mounting location for panel. If distance exceeds the length of either the sensor or float cables or the pump power cables, splicing will be required. **Note:** For splicing C-Level cord, use only shielded cable. Splice conductors as well as shielding. Maximum total cable length is 300 feet. For outdoor or wet installation, we recommend the use of an SJE-Rhombus® liquid-tight junction box with liquid-tight connectors to make required connections. **You must use conduit sealant to prevent moisture or gases from entering the panel.**
2. Mount control panel with mounting devices furnished.
3. Determine conduit entrance locations on control panel. Check local codes and schematic for the number of power circuits required. **(Sensor cable requires separate conduit from power and pump cables.)**

Note: Be sure the proper power supply voltage, amperage, and phase meet the requirements of the pump motor(s) being installed. If in doubt, see the pump identification plate for voltage/phase requirements.

4. Drill proper size holes for type of connectors being used.

Note: If using conduit, be sure that it is of adequate size to pull the pump cable(s) through.

5. Attach cable connectors and/or conduit connectors to control panel.

**FOR INSTALLATION REQUIRING A SPLICE, FOLLOW STEPS 6-10;
FOR INSTALLATION WITHOUT A SPLICE, GO TO STEP 11.**

Warranty void if panel is modified.

Call factory with servicing questions:

1-800-RHOMBUS
(1-800-746-6287)

Manufactured by:

SJE
Rhombus®

22650 County Highway 6 ■ P.O. Box 1708
Detroit Lakes, Minnesota 56502 USA
1-888-DIAL-SJE (1-888-342-5753)
Phone: 218-847-1317 ■ Fax: 218-847-4617
E-mail: customer.service@sjerhombus.com
Website: www.sjerhombus.com

©SJE-Rhombus
Printed in USA
1036677 • Rev B 12/14

Installation Instructions

6. Determine location for mounting junction box according to local code requirements. **Do not** mount the junction box inside the sump or basin.
7. Mount junction box to proper support.
8. Run conduit to junction box. Drill proper size holes for the type of conduit used.
9. Identify and label each wire before pulling through conduit into control panel and junction box. Make wire splice connections at junction box.
10. Firmly tighten all fittings on junction box.
11. If a junction box is not required, pull cables through conduit into control panel.
12. Connect pump wires per wiring diagram or schematic, and sensor or float wires to the proper terminals as shown on the schematic.
13. Connect pump, control, and alarm incoming power conductors to proper position on terminals. See schematic for terminal connections.

VERIFY CORRECT OPERATION OF CONTROL PANEL AFTER INSTALLATION IS COMPLETE.

Installation of C-Level Sensor and Floats

WARNING: Verify C-Level™ and IFS panel are matched with CL40 or CL100. Using wrong sensor with panel will cause settings to be incorrect.

CAUTION: If control switch cables are not wired and mounted in the correct order, the pump system will not function properly. Sensor and float cables need to run in separate conduit from pump and power lines.

Industry practices suggest that a secondary device, such as a float switch, be used for redundant activation of the high level alarm and pump shut off.

WARNING: Turn off all power before installing pump wires in pump chamber. Failure to do so could result in serious or fatal electrical shock.

NOTE: The C-Level™ sensor operates between 0 and 39.9 inches of water pressure for the CL40 or between 0 and 99.9 inches of water pressure for the CL100. The C-Level™ sensor reads 0 inches at the approximate point shown in **Figure 2**. As the liquid level rises, the IFS display shows depth of liquid from the zero point. The minimum set point for the stop (demand) or redundant off (timed dose) level is 4 inches (measured from 0) see **Figure 2**.

The maximum set point allowed is 39 inches (measured from 0) for the CL40 or 99 inches (measured from 0) for the CL100. Operating temperature range is 32°F (0°C) to 120°F (50°C).

1. Determine the nominal operating levels for the configuration, as illustrated in **Figure 3 or 4**.
2. Position C-Level sensor at appropriate location on pipe and secure sensor and vent as shown in **Figure 2** using hose clamps.

WARNING: Do not support the C-Level sensor by the cable. Position the sensor in the tank so that nothing is pushing in the diaphragm.

3. Position vent so it is above the water level and stow excess vent tube as shown in **Figure 2**.

WARNING: Do **NOT** kink or place black tubing under hose clamp. **Doing so will cause sensor to fail.**

4. If optional high water or redundant off floats are used, position and secure as shown in **Figures 1, 3 or 4**. Redundant off float should be located to activate at approximately the zero point for the C-Level per **Figure 3 or 4**.

NOTE: SJE-Rhombus® recommends using the optional high water alarm float for added protection against flooding.

5. Tighten all hose clamps using a screw driver. Over tightening may result in damage to the plastic parts.

NOTE: All hose clamp components are made of 18-8 stainless steel material. See your SJE-Rhombus® supplier for replacement parts.

6. Functionally test the system by filling the tank and witnessing proper operation.

Installation Instructions

Figure 1

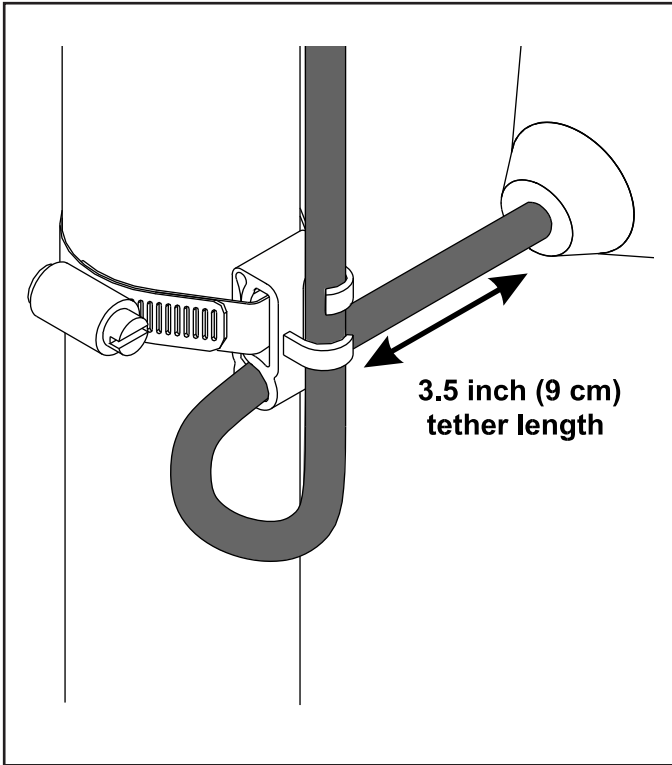

Figure 2

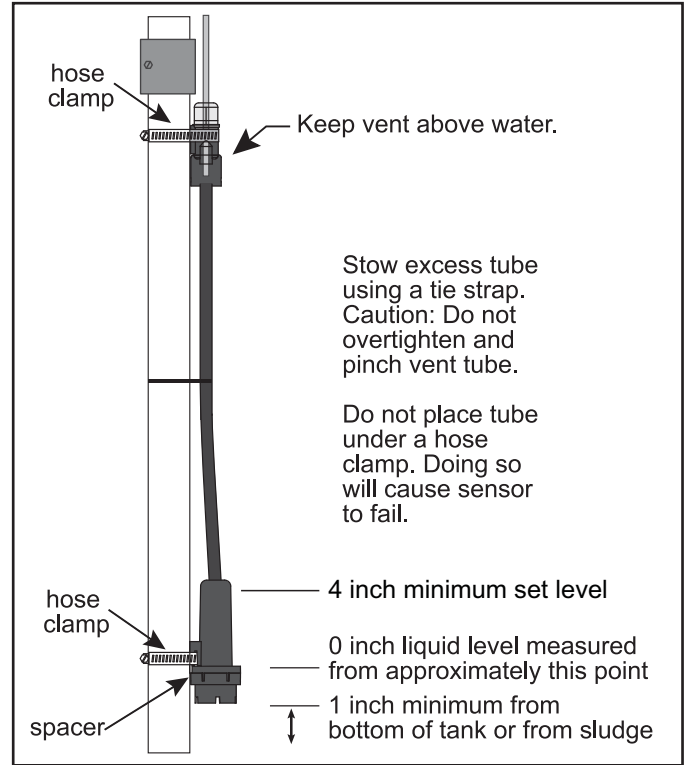

Figure 3 - Timed Dose

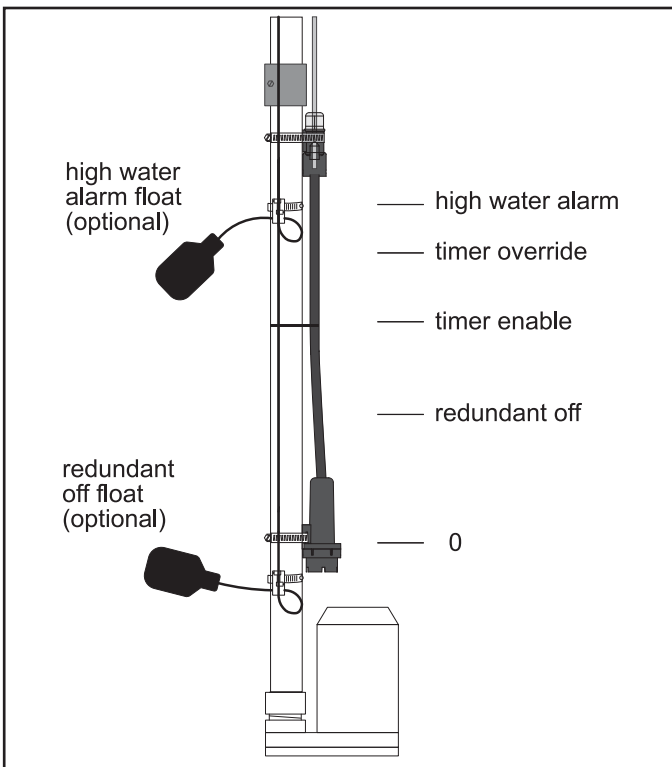
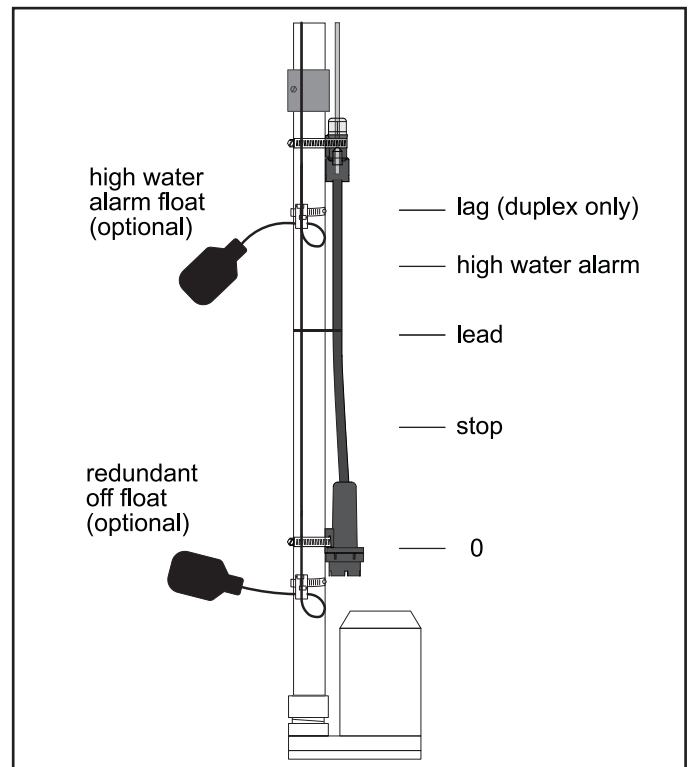

Figure 4 - Demand Dose



Operations

The Installer Friendly Series (IFS) control panel uses the C-Level sensor to continuously monitor and control the liquid level in the tank. An optional high water alarm float and redundant off float can be used to provide additional protection from high or low water conditions.

Hand Operation - The level must be above the stop/redundant off set point to put the panel in HAND operation. To override the stop/redundant off set point, press and hold the HAND button. The pump runs until the HAND button is released. The panel then returns to the AUTO mode. If the level is above the stop/redundant off set point and the panel is placed in the HAND mode, and left in HAND mode, the pump continues to run until the liquid level reaches the stop/redundant off set point. The panel then returns to the AUTO mode.

Off Operation - The panel is in the OFF mode.

Auto Operation - In time dose (t-dose) mode, when the panel is in the AUTO mode, the timer controls pump ON and OFF time as long as the redundant off and timer enable set points are activated. In demand (d-dose), the stop and lead set points control the pump.

Level Indicators - Illuminate if the corresponding set point is triggered.

Green Control and Alarm Power Indicators - (mounted on interior circuit board) Illuminates when control power and alarm power is present. If the control fuse needs replacing the panel sounds an alarm.

LED Display - Used to view and set panel settings and cycle count data. Will turn off after five minutes of non-use.

Viewing Panel Settings and Cycle Data

To view panel settings and cycle data press the **NEXT** button. Each time the **NEXT** button is pressed the display will advance to the next setting or cycle data. Information will be displayed in the following order:

in - Level of the liquid measured from the zero point on the sensor. This will be shown in inches or centimeters depending on the units selected.

t-dOSE or d-dOSE – Identifies if the panel is configured as a time dose or demand dose panel.

Et 1 – Elapsed time meter for pump 1 shown in hh:mm:ss.

CC 1 – Cycle count for pump 1.

AL 1Ctr – Cycle count for Duo Alarm 1 option for single phase models **OR**
Cycle count for Pump 1 Fail for three phase models and single phase models with overloads.

Et 2 – Elapsed time meter for pump 2 shown in hh:mm:ss (duplex only)

CC 2 – Cycle count for pump 2 (duplex only).

AL 2Ctr – Cycle count for Duo Alarm 2 option for single phase models **OR**
Cycle count for Pump 2 Fail for three phase models and single phase models with overloads.

AL-Ctr – Alarm counter which includes high water alarm, float error alarm, and Duo Alarm 1 and 2.

FE-Ct – Float error counter which counts how many times the water level drops below the bottom of the sensor and when the optional redundant off float opens.

tO-Ct – Timer override which counts how many times the liquid level has reached the timer override set point (time dose only).

On – On time currently set for the pump shown in hh:mm:ss (time dose only).

OFF – OFF time currently set for the pump shown in hh:mm:ss (time dose only).

t-OFF or t-On – Display counts down the OFF or On time remaining in the cycle (time dose only).

Operations

Programming Panel Settings

Entering the program mode:

Press and hold the **SET** button for 3 seconds until the “Prog” is displayed. The first parameter that can be set, along with its current value, will then flash on the display. You are now in the program mode.

Exiting the program mode:

At any point in the program mode push and hold the **SET** button for 3 seconds until run is displayed. The display will then return to its normal state.

To change and set a parameter:

NOTE: While setting parameters the following conditions must be met or the display will show (ERROR):

LAg	- level must be above LEAd for Demand Dose
LEAd	- level must be above StOP for Demand Dose
StOP	- level must be 4 inches or higher for Demand Dose
tO	- level must be above tEnbLE for Time Dose
tEnbLE	- level must be above rEdOFF for Time Dose
rEdOFF	- level must be 4 inches or higher for Time Dose.

1. When in the program mode push the NEXT button until the desired parameter is displayed.
2. Push the SET button and the current value of that parameter will be displayed with the first digit flashing.
3. Use the UP button to change the value of the flashing digit. When the desired value of the flashing digit is reached, push the NEXT button to advance to the next digit. Use the UP and NEXT buttons to set the total value of that parameter.
4. When done setting the parameter, push the set button and the parameter will flash along with its new value. If an (ERROR) message is received, check above conditions to ensure all are being met.
5. Push the NEXT button to advance to the next parameter and follow steps 2 – 4 to set the values.

Parameters that can be set:

The parameters that can be set when in the program mode are:

For Time Dose Panels:

On – On time for pump in hh:mm:ss

OFF – Off time for the pump in hh:mm:ss

ALtErn – Sets the alternation of the pumps. Settings are ALt, 2-1 and 1-2. (duplex panels only)

ALAr – High water alarm set point.

tO – Timer override set point

tEnbLE – Timer enable set point

rEdOFF – Redundant off set point.

UnitS – Units of measure can be set in inches (in) or centimeters (c).

For Demand Dose Panels:

ALtErn – Sets the alternation of the pumps. Settings are ALt, 2-1 and 1-2. (duplex panels only)

ALAr – High water alarm set point.

LAg – Lag pump start point. (duplex panels only)

LEAd – Lead pump start point.

StOP – Pump stop set point.

UnitS – Units of measure can be set in inches (in) or centimeters (c).

Operations

Selecting Time Dose or Demand Dose -Panels in the field

To set the panel to either Timed Dose or Demand Dose in the field:

1. Turn the control/alarm power off to the control panel.
2. Turn the pump power off to the control panel.
3. Place a small screwdriver or pen into the slot in the label on the inner door marked "DEMAND DOSE TIMED DOSE".
 - Move the dip switch (up) for demand dose
 - Move the dip switch (down) for Timed dose

4. Turn the control/alarm power on to the control panel. After the display goes blank press the "NEXT" switch.
 - The display will show d-dose for demand dose.
 - The display will show t-dose for timed dose.**WARNING:** Changing the dip switch positions will change the operation of the panel.
WARNING: If changing to timed dose, be sure to set the off and on times.
5. Turn on the pump power after all the settings are changed.
6. **WARNING:** Check the panel for correct operation before leaving the site.

Troubleshooting

C-Level Sensor

1. Verify that the black tube is not kinked or has any holes in it. If either condition exists, the pressure sensor may fail or give inaccurate level readings.
2. Vent must be above water and unobstructed. This is required to compensate for barometric pressure changes. Obstructing the vent will result in inaccurate level readings.
3. The black diaphragm is located on the end of the sensor body. The diaphragm must not be damaged or deformed. A damaged or deformed diaphragm will result in inaccurate level readings.
4. Verify the bottom of the C-Level Sensor is not resting on the bottom of the tank or on any other obstacle.
5. Verify that the electrical cable is not damaged or severed.
6. Verify that the shielding for cable is properly attached to ground.

7. If the panel includes the optional redundant off float, verify that the float is properly wired to the panel.

Fuse

To check the continuity of the fuse, pull the fuse out of the fuse holder. With the ohmmeter on the R X 1 scale, measure resistance. A reading of infinity (high resistance) indicates a blown fuse that must be replaced with a fuse of the same type, voltage, and amp rating.

Alarm Light

With power on, hold the test/normal/silence switch in the "test" position. The alarm light should turn on. If not, replace the light with that of the same type.

Alarm Horn

With power on, hold the test/normal/silence switch in the "test" position. The alarm horn should turn on. If not, replace the horn with that of the same type.



Septic System Compliance Inspection – Existing System

Date: 7/31/2020

Property Owner: Don Casey

Ordered By: Kathy Sparks

Address: 49131 373rd Place Palisade MN 56469

Property ID#: 35-0-027512

Inspector: Tim Woodrow

A compliance inspection was performed at the above location. Soil evaluation was conducted to determine the level of seasonal saturated soil. The Soil Treatment Area (Drainfield) was also inspected to ensure there was no ponding or leaking. The septic tank was pumped and inspected. This onsite system was found to be **NON-Compliant.**

- **Impact On Public Health:**
System is Complaint
- **Tank Integrity:**
Tank(s) are compliant
- **Other Compliance Conditions:**
None
- **Soil Separation**
Soils are Not complaint
- **Operating Permit and Nitrogen BMP**
NA

I have included a copy of the compliance documents for your record. I have also sent a copy to Aitkin County for their records. If you have any questions, please do not hesitate to give us a call.

Thanks!

A handwritten signature in blue ink, appearing to read "Tim Woodrow", is written over a horizontal line.

Tim Woodrow
Owner

218-927-6175



Minnesota Pollution Control Agency

520 Lafayette Road North
St. Paul, MN 55155-4194

Compliance Inspection Form
Existing Subsurface Sewage Treatment Systems (SSTS)

Doc Type: Compliance and Enforcement

Inspection results based on Minnesota Pollution Control Agency (MPCA) requirements and attached forms – additional local requirements may also apply.

Submit completed form to Local Unit of Government (LUG) and system owner within 15 days

For local tracking purposes:

System Status

System status on date (mm/dd/yyyy): 7/31/2020

[] Compliant – Certificate of Compliance
(Valid for 3 years from report date, unless shorter time frame outlined in Local Ordinance.)

[X] Noncompliant – Notice of Noncompliance
(See Upgrade Requirements on page 3.)

Reason(s) for noncompliance (check all applicable)

- [] Impact on Public Health (Compliance Component #1) – Imminent threat to public health and safety
[] Other Compliance Conditions (Compliance Component #3) – Imminent threat to public health and safety
[] Tank Integrity (Compliance Component #2) – Failing to protect groundwater
[] Other Compliance Conditions (Compliance Component #3) – Failing to protect groundwater
[X] Soil Separation (Compliance Component #4) – Failing to protect groundwater
[] Operating permit/monitoring plan requirements (Compliance Component #5) – Noncompliant

Property Information

Parcel ID# or Sec/Twp/Range: 35-0-027512

Property address: 49131 373rd Place Palisade MN 56469 Reason for inspection: Transfer

Property owner: Don Casey Owner's phone:

or

Owner's representative: Kathy Sparks Representative phone: 218-851-3232

Local regulatory authority: Aitkin County Regulatory authority phone: 218-927-7342

Brief system description: 1000 Septic to a 250 Lift to a 20x25 Pressure Bed

Comments or recommendations:

Certification

I hereby certify that all the necessary information has been gathered to determine the compliance status of this system. No determination of future system performance has been nor can be made due to unknown conditions during system construction, possible abuse of the system, inadequate maintenance, or future water usage.

Inspector name: Tim Woodrow Certification number: C7644

Business name: Gobles Sewer Service License number: L455

Inspector signature: [Signature] Phone number: 218-927-6175

Necessary or Locally Required Attachments

- [X] Soil boring logs [X] System/As-built drawing [] Forms per local ordinance
[X] Other information (list): Tank report

1. Impact on Public Health – Compliance component #1 of 5

Compliance criteria:

System discharges sewage to the ground surface.	<input type="checkbox"/> Yes <input checked="" type="checkbox"/> No
System discharges sewage to drain tile or surface waters.	<input type="checkbox"/> Yes <input checked="" type="checkbox"/> No
System causes sewage backup into dwelling or establishment.	<input type="checkbox"/> Yes <input checked="" type="checkbox"/> No

Any "yes" answer above indicates the system is an imminent threat to public health and safety.

Comments/Explanation:

Verification method(s):

- Searched for surface outlet
- Searched for seeping in yard/backup in home
- Excessive ponding in soil system/D-boxes
- Homeowner testimony (See Comments/Explanation)
- "Black soil" above soil dispersal system
- System requires "emergency" pumping
- Performed dye test
- Unable to verify (See Comments/Explanation)
- Other methods not listed (See Comments/Explanation)

2. Tank Integrity – Compliance component #2 of 5

Compliance criteria:

System consists of a seepage pit, cesspool, drywell, or leaching pit. <i>Seepage pits meeting 7080.2550 may be compliant if allowed in local ordinance.</i>	<input type="checkbox"/> Yes <input checked="" type="checkbox"/> No
Sewage tank(s) leak below their designed operating depth. If yes, which sewage tank(s) leaks:	<input type="checkbox"/> Yes <input checked="" type="checkbox"/> No

Any "yes" answer above indicates the system is failing to protect groundwater.

Comments/Explanation:

See attached tank report

Verification method(s):

- Probed tank(s) bottom
- Examined construction records
- Examined Tank Integrity Form (Attach)
- Observed liquid level below operating depth
- Examined empty (pumped) tanks(s)
- Probed outside tank(s) for "black soil"
- Unable to verify (See Comments/Explanation)
- Other methods not listed (See Comments/Explanation)

3. Other Compliance Conditions – Compliance component #3 of 5

- a. Maintenance hole covers are damaged, cracked, unsecured, or appear to be structurally unsound. Yes* No Unknown
- b. Other issues (electrical hazards, etc.) to immediately and adversely impact public health or safety. Yes* No Unknown
***System is an imminent threat to public health and safety.**

Explain:

- c. System is non-protective of ground water for other conditions as determined by inspector. Yes* No
***System is failing to protect groundwater.**

Explain:

4. Soil Separation – Compliance component #4 of 5

Date of installation: _____ Unknown
(mm/dd/yyyy)

Shoreland/Wellhead protection/Food beverage lodging? Yes No

Compliance criteria:

For systems built prior to April 1, 1996, and not located in Shoreland or Wellhead Protection Area or not serving a food, beverage or lodging establishment:
 Yes No
Drainfield has at least a two-foot vertical separation distance from periodically saturated soil or bedrock.

Non-performance systems built April 1, 1996, or later or for non-performance systems located in Shoreland or Wellhead Protection Areas or serving a food, beverage, or lodging establishment:
 Yes No
Drainfield has a three-foot vertical separation distance from periodically saturated soil or bedrock.*

“Experimental”, “Other”, or “Performance” systems built under pre-2008 Rules; Type IV or V systems built under 2008 Rules (7080.2350 or 7080.2400 (Advanced Inspector License required)
 Yes No
Drainfield meets the designed vertical separation distance from periodically saturated soil or bedrock.

Verification method(s):

Soil observation does not expire. Previous soil observations by two independent parties are sufficient, unless site conditions have been altered or local requirements differ.

- Conducted soil observation(s) (Attach boring logs)
- Two previous verifications (Attach boring logs)
- Not applicable (Holding tank(s), no drainfield)
- Unable to verify (See Comments/Explanation)
- Other (See Comments/Explanation)

Comments/Explanation:

Indicate depths or elevations

A. Bottom of distribution media	100
B. Periodically saturated soil/bedrock	99.9'
C. System separation	.1'
D. Required compliance separation*	31" (2.55')

*May be reduced up to 15 percent if allowed by Local Ordinance.

Any “no” answer above indicates the system is failing to protect groundwater.

5. Operating Permit and Nitrogen BMP* – Compliance component #5 of 5 **Not applicable**

Is the system operated under an Operating Permit? Yes No **If “yes”, A below is required**

Is the system required to employ a Nitrogen BMP? Yes No **If “yes”, B below is required**

BMP = Best Management Practice(s) specified in the system design

If the answer to both questions is “no”, this section does not need to be completed.

Compliance criteria

- a. Operating Permit number: _____
Have the Operating Permit requirements been met? Yes No
- b. Is the required nitrogen BMP in place and properly functioning? Yes No

Any “no” answer indicates Noncompliance.

Upgrade Requirements (Minn. Stat. § 115.55) *An imminent threat to public health and safety (ITPHS) must be upgraded, replaced, or its use discontinued within ten months of receipt of this notice or within a shorter period if required by local ordinance. If the system is failing to protect ground water, the system must be upgraded, replaced, or its use discontinued within the time required by local ordinance. If an existing system is not failing as defined in law, and has at least two feet of design soil separation, then the system need not be upgraded, repaired, replaced, or its use discontinued, notwithstanding any local ordinance that is more strict. This provision does not apply to systems in shoreland areas, Wellhead Protection Areas, or those used in connection with food, beverage, and lodging establishments as defined in law.*

SKETCH SHEET AND SOIL BORING LOG



INSPECTOR: Tim Woodrow	Equipment: Bucket Auger
DATE: 7/31/2020	Elevation of Limiting Layer: 99.9
PID#: 35-0-027512	Vegetation: Mowed Grass
SITE ADDRESS: 49131 373 rd Place Palisade MN 56469	Weather: Sunny & Clear
Benchmark (EL = 100'): Bottom of Rock in STA	

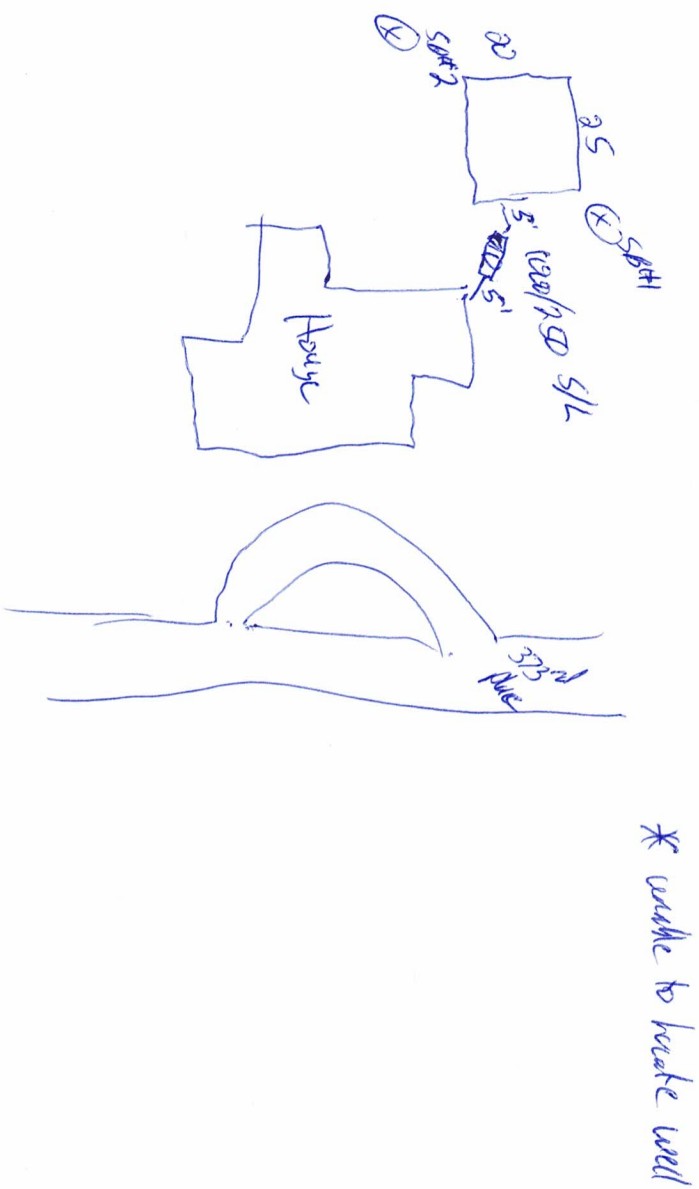

SOIL BORING #1 EL: 101.8

DEPTH	TEXTURE	COLOR
0-6"	Topsoil	10YR3/2
6-20"	Sand (M)	10YR5/4
20-34"	Sand (M)	10YR5/3
34"	Sand (M)	10YR6/1
	Redox @ 22" EL: 99.9'	5YR5/4

SOIL BORING #2 EL: 100.9

DEPTH	TEXTURE	COLOR
0-3"	Topsoil	10YR3/2
3-24"	Sand(C)	7.5YR5/6
24-30"	Sand(M)	10YR5/2
	Redox @ 24"	5YR5/4

Goble's Sewer Service inc.

1037 1st Street NW
Aitkin, MN 56431 License # 455
927-6175 800-713-5234
MPCA registered company

Septic tank fact sheet:

Tim Woodrow

System inspector or installer

Current septic tank owner: Don Casey

Site address: 49131 373rd Place
Palisade MN 56469

Phone number: 218-845-2642

Tank type: Precast Concrete Combo

Approx. size (gallons): 1000/250

Approx. age:

Lift station (how many): Yes(1)

Our procedure for inspecting a septic tank is as follows.

Open the access cover.

Clean the septic and lift tanks removing all of the solid and liquid waste.

Do a fresh water rinse (not available during cold winter months).

Look at the septic & or lift tank from the access opening looking for cracks, breaks or other signs of deterioration.

Check to see if the baffles are still functional.

Replace the access cover.

Defects are listed below:

NONE

Recommendations or comments:

Tank is ok and does not appear to leak.

Observed by:

Craig Perlberg(Jeremy Goble)

Observation date:

July 23, 2020

Note: This tank appears water tight within the normal operating range of the tank, there are no guarantees that it will keep ground water out.

Note: This is a septic tank fact sheet, not a complete sewer system inspection form and does not replace a complete sewer inspection for transfer of property. In some instances, this form may be used in conjunction with a sewer inspection.