

BILL OF MATERIALS

- 6 12" Throat Tile
- 1 24x24 S.C.
- 1 48" Vestal Damper
- 1 Modified Damper Handle
- 1 Left Coving
- 1 Right Coving
- 24x24 Flues (as needed)

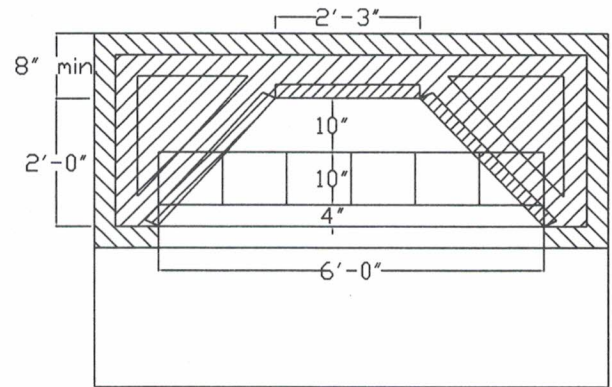

#17

Note: supply adequate make up air