

Subsurface Sewage Treatment System Management Plan

Property Owner: LORNE Henkel Phone: 763-218-9238 Date: 5-28-2019
Mailing Address: 13023 ST Hwy 18 City: Finlayson Zip: 55735
Site Address: 13023 ST Hwy 18 City: Finlayson Zip: 55735

This management plan will identify the operation and maintenance activities necessary to ensure long-term performance of your septic system. Some of these activities must be performed by you, the homeowner. Other tasks must be performed by a licensed septic service provider or maintenance provider.

System Designer: Recommends SSTS check every 36 months.
Local Government: Recommends SSTS check every 36 months.
State Requirement: Requires SSTS check every 36 months.
(State requirements are based on MN Rules Chapter 7080.2450, Subp. 2 & 3)

**My System needs to be checked
every 36 months.**

Homeowner Management Tasks:

Leaks – Check (look, listen) for leaks in toilets and dripping faucets. Repair leaks promptly.

Surfacing sewage – Regularly check for wet or spongy soil around your soil treatment area.

Effluent filter – *Inspect and clean twice a year or more.*

Alarms – Alarm signals when there is a problem. Contact a service or maintenance provider any time an alarm signals.



Event counter or water meter – Record your water use.

-recommend meter readings be conducted (circle one): DAILY WEEKLY MONTHLY N/A

Licensed septic service provider or maintenance provider (Check all that apply):

- Check to make sure tank is not leaking
- Check and clean the in-tank effluent filter (if exists)
- Check the sludge/scum layer levels in all septic tanks
- Recommend if tank should be pumped
- Check inlet and outlet baffles
- Check the drainfield effluent levels in the rock layer
- Check the pump and alarm system functions
- Check wiring for corrosion and function
- Check dissolved oxygen and effluent temperature in tank
- Provide homeowner with list of results and any action to be taken
- Flush and clean laterals if cleanouts exist

"I understand it is my responsibility to properly operate and maintain the sewage treatment system on this property, utilizing the Management Plan. If requirements in the Management Plan are not met, I will promptly notify the permitting authority and take necessary corrective actions. If I have a new system, I agree to adequately protect the reserve area for future use as a soil treatment system."

Property Owner Signature:  Date: 5-15-2019
Designer Signature:  Date: 5/28/2019

See Reverse Side for Management Log

FIELD EVALUATION SHEET

PRELIMINARY EVALUATION DATE 10-2018 FIELD EVALUATION DATE 5-15-2019
PROPERTY OWNER: LORNE HENKEL PHONE 762-218-9238
ADDRESS: 13023 ST Hwy 19 CITY, STATE, ZIP: WINLAGSON
LEGAL DESCRIPTION:
PIN# 34-0-025400 SEC 16 T 47 R 22 TWP NAME WAGNER
FIRE# LAKE/RIVER LAKE CLASS OHWL FT.

DESCRIPTION OF SOIL TREATMENT AREAS

	AREA #1	AREA #2	REFERENCE BM ELEV. <u>100</u> FT.
DISTURBED AREAS:	YES <u>NO</u> X	YES <u>NO</u>	REFERENCE BM DESCRIPTION <u>Bottom of slope</u>
COMPACTED AREAS	YES <u>NO</u> X	YES <u>NO</u>	
FLOODING	YES <u>NO</u> X	YES <u>NO</u>	
RUN ON POTENTIAL	YES <u>NO</u> X	YES <u>NO</u>	
SLOPE %	<u>6%</u>		
DIRECTION OF SLOPE	<u>West</u>		
LANDSCAPE POSITION	<u>Side Slope</u>		
VEGETATION TYPES	<u>Lawn Grass</u>		

DEPTH TO STANDING WATER OR MOTTLED SOIL: BORING# 1 20", 1A 26", 2 2A

BOTTOM ELEVATION: FIRST TRENCH OR BOTTOM OF ROCK BED: #1 +18 FT., #2 FT.

SOIL SIZING FACTOR: SITE #1 1.27, SITE #2 FT.

CONSTRUCTION RELATED ISSUES: _____

LIC# < 2006 SITE EVALUATOR SIGNATURE: Dave English

SITE EVALUATOR NAME: Dave English TELEPHONE# 572-3606

LUG REVIEW _____ DATE _____

Comments: _____

SOIL BORING LOGS ON REVERSE SIDE

MOUND DESIGN WORK SHEET (For Flows up to 1200 gpd)

A. Average Design FLOW

Estimated 450 gpd (see figure A-1)
 or measured _____ x 1.5 (safety factor) = _____ gpd

A-1: Estimated Sewage Flows in Gallons per Day

number of bedrooms	Class I	Class II	Class III	Class IV
2	300	225	180	60%
3	450	300	218	of the
4	600	375	256	values
5	750	450	294	in the
6	900	525	332	Class I,
7	1050	600	370	II, or III
8	1200	675	408	columns.

B. SEPTIC TANK Capacity

1,000 gallons (see figure C-1)

C-1: Septic Tank Capacities (in gallons)

Number of Bedrooms	Minimum Liquid Capacity	Liquid capacity with garbage disposal	Liquid capacity with disposal & lift inside
2 or less	750	1125	1500
3 or 4	1000	1500	2000
5 or 6	1500	2250	3000
7, 8 or 9	2000	3000	4000

C. SOILS (refer to site evaluation)

- Depth to restricting layer = 1.8 feet
- Depth of percolation tests = _____ feet
- Texture Sand silt
 Percolation rate 1.5 mpi
- Soil loading rate 1.77 gpd/sqft (see figure D-33)
- Percent land slope 6 %

D. ROCK LAYER DIMENSIONS

- Multiply average design flow (A) by 0.83 to obtain required rock layer area.
450 gpd x 0.83 sqft/gpd = 375 sqft
- Determine rock layer width = 0.83 sqft/gpd x linear Loading Rate (LLR)
 0.83 sqft/gpd x 12 gpd/sqft = 10 ft
- Length of rock layer = area ÷ width =
380 sqft (D1) ÷ 10 ft (D2) = 38 ft

Mound LLR	
< 120 MPI	≤ 12
≥ 120 MPI	≤ 6

E. ROCK VOLUME

- Multiply rock area (D1) by rock depth of 1 ft to get cubic feet of rock
380 sqft x 1 ft = 380 cuft
- Divide cuft by 27 cuft/cuyd to get cubic yards
380 cuft ÷ 27 cuyd/cuft = 14.1 cuyd
- Multiply cubic yards by 1.4 to get weight of rock in tons
14.1 cuyd x 1.4 ton/cuyd = 19.7 tons

F. SEWAGE ABSORPTION WIDTH

Absorption width equals absorption ratio (See Figure D-33) times rock layer width (D2)

10 x 1.5 ft = 15 ft

D-33: Absorption Width Sizing Table

Percolation Rate in Minutes per Inch (MPI)	Soil Texture	Loading Rate Gallons per day per square foot	Absorption Ratio
Faster than 5	Coarse Sand Medium Sand Loamy Sand Fine Sand	1.20	1.00
<u>6 to 15</u>	<u>Sandy Loam</u>	<u>0.79</u>	<u>1.50</u>
16 to 30	Loam	0.70	2.00
31 to 45	Silt Loam Silt	0.50	2.40
46 to 60	Sandy Clay Loam Silty Clay Loam Clay Loam	0.45	2.67
61 to 120	Silty Clay Sandy Clay Clay	0.24	3.00
Slower than 120*			

*System designed for these soils must be other or performance

G. MOUND SLOPE WIDTH & LENGTH

Landslope > 1% slope

(landslope greater than 1%)

1. Downslope absorption width = absorption width (F) minus rock layer width (D2)

$15 \text{ ft} - 10 \text{ ft} = 5 \text{ ft}$

2. Calculate mound size

UPSLOPE

a. Depth of clean sand fill at upslope edge of rock layer = 3 ft minus the distance to restricting layer (C1)

$3 \text{ ft} - 1.5 \text{ ft} = 1.5 \text{ ft}$

b. Mound height at the upslope edge of rock layer = depth of clean sand for separation (G2a) at upslope edge plus depth of rock layer (1 ft) plus depth of cover (1 ft)

$1.5 \text{ ft} + 1 \text{ ft} + 1 \text{ ft} = 3.5 \text{ ft}$

c. Upslope berm multiplier based on land slope

3.23 (see figure D-34)

d. Upslope width = berm multiplier (G2c) x upslope mound height (G2b):

$3.23 \times 3.5 \text{ ft} = 11.3 \text{ ft}$

DOWNSLOPE

e. Drop in elevation = rock layer width (D2) x percent landslope (C5) = 100

$10 \text{ ft} \times 6\% + 100 = 1.6 \text{ ft}$

f. Downslope mound height = depth of clean sand for slope difference (G2e) at downslope rock edge plus the mound height at the upslope edge of rock layer (G2b)

$3.5 \text{ ft} + 1.6 \text{ ft} = 5.1 \text{ ft}$

g. Downslope berm multiplier based on percent land slope

5.26 (see figure D-34)

h. Downslope width = downslope multiplier (G2g) times downslope mound height (G2f)

$5.1 \times 5.26 \text{ ft} = 26.6 \text{ ft}$

i. Select the greater of G1 and G2h as the downslope width: 21.6 ft

j. Total mound width is the sum of upslope width (G2d) width plus rock layer width (D2) plus downslope width (G2i).

$11.3 \text{ ft} + 10 \text{ ft} + 21.6 \text{ ft} = 42.9 \text{ ft}$

k. Total mound length is the sum of upslope width (G2d) plus rock layer length (D3) plus upslope width (G2d)

$14 \text{ ft} + 38 \text{ ft} + 14 \text{ ft} = 66 \text{ feet}$

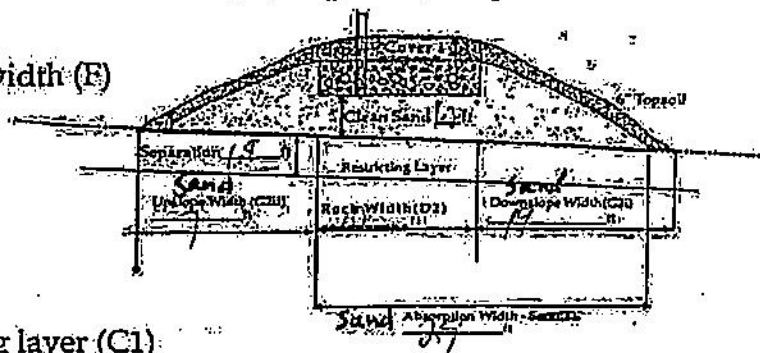

D-34: SLOPE MULTIPLIER TABLE

Land Slope, in %	UPSLOPE multipliers for various slope ratios						DOWNSLOPE multipliers for various slope ratios				
	3:1	4:1	5:1	6:1	7:1	8:1	3:1	4:1	5:1	6:1	7:1
0	3.0	4.0	5.0	6.0	7.0	8.0	3.0	4.0	5.0	6.0	7.0
1	2.91	3.85	4.76	5.66	6.54	7.41	3.09	4.17	5.26	6.38	7.53
2	2.83	3.70	4.54	5.38	6.14	6.90	3.19	4.35	5.56	6.82	8.14
3	2.75	3.57	4.35	5.08	5.79	6.45	3.30	4.54	5.88	7.32	8.86
4	2.68	3.45	4.17	4.81	5.46	6.06	3.41	4.76	6.25	7.89	9.72
5	2.61	3.33	4.00	4.62	5.19	5.71	3.53	5.00	6.67	8.57	10.77
6	2.54	3.23	3.85	4.41	4.93	5.41	3.66	5.26	7.14	9.38	12.07
7	2.48	3.12	3.70	4.23	4.70	5.13	3.80	5.56	7.69	10.34	13.73
8	2.42	3.03	3.57	4.05	4.49	4.88	3.95	5.88	8.33	11.54	15.91
9	2.36	2.94	3.45	3.90	4.30	4.65	4.11	6.25	9.09	13.04	18.92
10	2.31	2.86	3.33	3.75	4.12	4.44	4.29	6.67	10.00	15.00	23.33
11	2.26	2.78	3.23	3.61	3.95	4.26	4.48	7.14	11.11	17.65	30.43
12	2.21	2.70	3.12	3.49	3.80	4.08	4.69	7.69	12.50	21.43	43.75

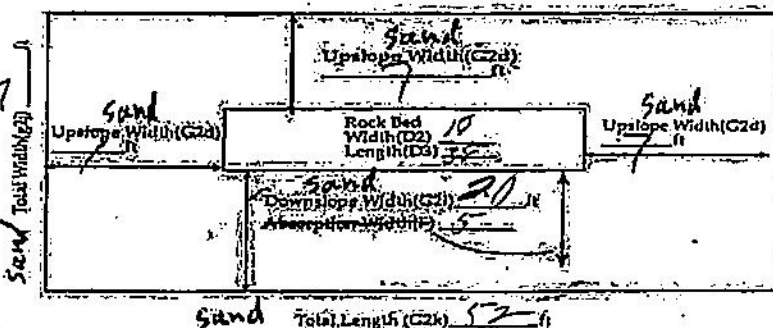

Final Dimensions:
66 x 42.9

I hereby certify that I have completed this work in accordance with applicable ordinances, rules and laws.
 [Signature] (signature) 42005 (license #) 5/28/2019 (date)

PRESSURE DISTRIBUTION SYSTEM

Geotextile fabric

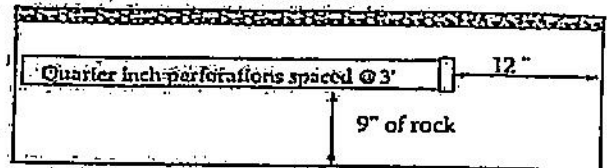

Perf Sizing 3/16" - 1/4"
Perf Spacing 1.5' - 5'

E-4: Maximum allowable number of 1/4-inch perforations per lateral to guarantee <10% discharge variation,

perforation spacing (feet)	1 inch	1.25 inch	1.5 inch	2.0 inch
2.5	8	14	18	28
3.0	8	13	17	26
3.3	7	12	16	25
4.0	7	11	15	23
5.0	6	10	14	22

- Select number of perforated laterals 3
- Select perforation spacing = 3 ft
- Since perforations should not be placed closer than 1 foot to the edge of the rock layer (see diagram), subtract 2 feet from the rock layer length.

$$\frac{38}{\text{Rock layer length}} - 2 \text{ ft} = 36 \text{ ft}$$

- Determine the number of spaces between perforations. Divide the length (3) by perforation spacing (2) and round down to nearest whole number.

$$\text{Perforation spacing} = 36 \text{ ft} \div 3 \text{ ft} = 12 \text{ spaces}$$

- Number of perforations is equal to one plus the number of perforation spaces(4). Check figure E-4 to assure the number of perforations per lateral guarantees <10% discharge variation.

$$12 \text{ spaces} + 1 = 13 \text{ perforations/lateral}$$

- A. Total number of perforations = perforations per lateral (5) times number of laterals (1)

$$13 \text{ perfs/lat} \times 3 \text{ lat} = 39 \text{ perforations}$$

- B. Calculate the square footage per perforation.

Should be 6-10 sqft/perf. Does not apply to at-grades.

Rock bed area = rock width (ft) x rock length (ft)

$$10 \text{ ft} \times 38 \text{ ft} = 380 \text{ sqft}$$

Square foot per perforation = Rock bed area + number of perfs (6)

$$380 \text{ sqft} \div 39 \text{ perfs} = 9.7 \text{ sqft/perf}$$

- Determine required flow rate by multiplying the total number of perforations (6A) by flow per perforation (see figure E-6)

$$39 \text{ perfs} \times .74 \text{ gpm/perfs} = 28.86 \text{ gpm}$$

- If laterals are connected to header pipe as shown on upper example, to select minimum required lateral diameter; enter figure E-4 with perforation spacing (2) and number of perforations per lateral (5) Select minimum diameter for perforated lateral = 1 1/2 inches.

- If perforated lateral system is attached to manifold pipe near the center, lower diagram, perforated lateral length (3) and number of perforations per lateral (5) will be approximately one half of that in step 8. Using these values, select minimum diameter for perforated lateral = _____ inches.

E-6: Perforation Discharge in gpm

head (feet)	perforation diameter (inches)			
	1/8	3/16	7/32	1/4
1.0 ^a	0.18	0.42	0.56	0.74
2.0 ^b	0.26	0.59	0.80	1.04
5.0	0.41	0.94	1.26	1.65

^a Use 1.0 foot for single-family homes.
^b Use 2.0 feet for anything else.

MANIFOLD LOCATED AT END OF PRESSURE DISTRIBUTION SYSTEM

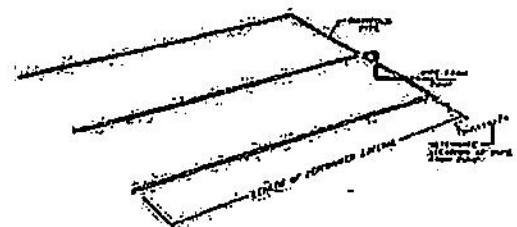

LAYOUT OF PERFORATED PIPE LATERALS FOR PRESSURE DISTRIBUTION IN MANIFOLD

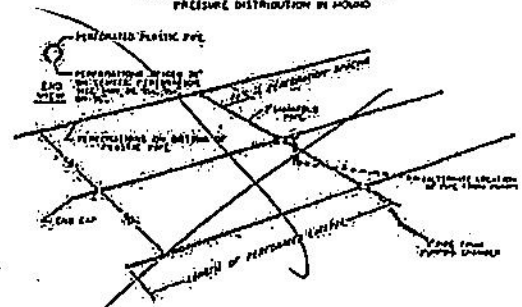

I hereby certify that I have completed this work in accordance with applicable ordinances, rules and laws.

David D. Dill (Signature) LA006 (license #) 5/28/2019 (date)

PUMP SELECTION PROCEDURE

1. Determine pump capacity:

A. Gravity distribution

1. Minimum required discharge is 10 gpm
2. Maximum suggested discharge is 45 gpm. For other establishments at least 10% greater than the water supply rate, but no faster than the rate at which effluent will flow out of the distribution device.

B. Pressure distribution

See pressure distribution work sheet

From A or B Selected pump capacity: 28.86 gpm

2. Determine pump head requirements:

A. Elevation difference between pump and point of discharge?

7 feet

B. Special head requirement? (See Figure at right - Special Head Requirements)

5 feet

C. Calculate Friction loss

1. Select pipe diameter 2 in

2. Enter Figure E-9 with gpm (1A or B) and pipe diameter (C1).

Read friction loss in feet per 100 feet from Figure E-9

Friction Loss = _____ ft/100ft of pipe

3. Determine total pipe length from pump discharge to soil treatment discharge point. Estimate by adding 25 percent to pipe length for fitting loss. Total pipe length times 1.25 = equivalent pipe length

25 feet x 1.25 = 31.25 feet

4. Calculate total friction loss by multiplying friction loss (C2) in ft/100 ft by the equivalent pipe length (C3) and divide by 100.

= 31.25 ft/100ft x 1.55 + 100 = 145 ft

D. Total head required is the sum of elevation difference (A), special head requirements (B), and total friction loss (C4)

7 ft + 5 ft + 145 ft =

Total head: 145 feet

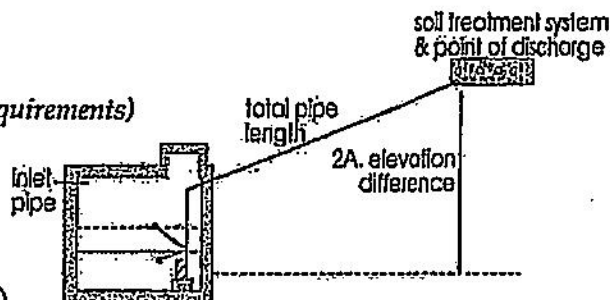

Special Head Requirements	
Gravity Distribution	0 ft
Pressure Distribution	5 ft

flow rate gpm	E-9: Friction Loss in Plastic Pipe Per 100 feet		
	nominal pipe diameter		
	1.5"	2"	3"
20	2.47	0.73	0.11
25	3.73	1.11	0.16
30	5.23	1.55	0.23
35	6.96	2.06	0.30
40	8.91	2.64	0.39
45	11.07	3.28	0.48
50	13.46	3.99	0.58
55		4.76	0.70
60		5.60	0.82
65		6.48	0.95
70		7.44	1.09

3. Pump selection

A pump must be selected to deliver at least 28.86 gpm (1A or B) with at least 145 feet of total head (2D)

I hereby certify that I have completed this work in accordance with applicable ordinances, rules and laws.

Barry E. [Signature]

(signature)

60006 (license #)

5/28/2019 (date)

