

FIELD EVALUATION SHEET

PRELIMINARY EVALUATION DATE 4/16/16 FIELD EVALUATION DATE 4/16/16
 PROPERTY OWNER: Harvey Boyd PHONE 715-220-9000
 ADDRESS: 23229 Hwy 47 CITY, STATE, ZIP: Aitkin MN 56431
 LEGAL DESCRIPTION: 10 AC of SE-SE in Doc 433265
 PIN# 21-0-048500 SEC 29 T 45 R 25 TWP NAME Malmo
 FIRE# _____ LAKE/RIVER _____ LAKE CLASS _____ OHWL _____ FT.

DESCRIPTION OF SOIL TREATMENT AREAS

	AREA #1	AREA #2	REFERENCE BM ELEV. <u>100</u> FT.
DISTURBED AREAS	YES _____ NO <input checked="" type="checkbox"/>	YES _____ NO <input checked="" type="checkbox"/>	REFERENCE BM DESCRIPTION _____
COMPACTED AREAS	YES _____ NO <input checked="" type="checkbox"/>	YES _____ NO <input checked="" type="checkbox"/>	<u>Ground at</u>
FLOODING	YES _____ NO <input checked="" type="checkbox"/>	YES _____ NO <input checked="" type="checkbox"/>	<u>NW corner of</u>
RUN ON POTENTIAL	YES _____ NO <input checked="" type="checkbox"/>	YES _____ NO <input checked="" type="checkbox"/>	<u>House</u>
SLOPE %	<u>4</u>	<u>2</u>	_____
DIRECTION OF SLOPE	<u>N</u>	<u>N</u>	_____
LANDSCAPE POSITION	<u>Crest</u>	<u>Slope</u>	_____
VEGETATION TYPES	<u>Wooded</u>	<u>Wooded</u>	_____

DEPTH TO STANDING WATER OR MOTTLED SOIL: BORING# 1 18", 1A 18", 2 18", 2A 17"

BOTTOM ELEVATION—FIRST TRENCH OR BOTTOM OF ROCK BED: #1 _____ FT., #2 _____ FT.

SOIL SIZING FACTOR: SITE #1 1.27, SITE #2 1.27

CONSTRUCTION RELATED ISSUES: _____

LIC# 663 SITE EVALUATOR SIGNATURE: Greg Westerlund
 SITE EVALUATOR NAME: Greg Westerlund TELEPHONE# 218-839-9460
 LUG REVIEW RA DATE 6/7/16

Comments: _____

SOIL BORING LOGS ON REVERSE SIDE

SOILS CHARTS FOR BOTH PROPOSED AND ALTERNATE SITES

1 (PROPOSED) SOILS DATA

DEPTH (INCHES)	TEXTURE	MUNSELL COLOR
6	loam	10YR 2/2
18	Sand loam	10YR 4/4
19	Mottle Soil	

2 (PROPOSED) SOILS DATA

DEPTH (INCHES)	TEXTURE	MUNSELL COLOR
7	loam	10YR 2/2
18	Sand loam	10YR 4/4
19	Mottle Soil	

1 (ALTERNATE) SOILS DATA

DEPTH (INCHES)	TEXTURE	MUNSELL COLOR
8	loam	10YR 2/2
18	Sand loam	10YR 4/4
19	Mottle Soil	

2 (ALTERNATE) SOILS DATA

DEPTH (INCHES)	TEXTURE	MUNSELL COLOR
8	loam	10YR 2/2
17	Sand loam	10YR 4/4
18	Mottle Soil	

ADDITIONAL SOIL BORINGS MAY BE REQUIRED

MOUND DESIGN WORK SHEET (For Flows up to 1200 gpd)

A. Average Design FLOW

Estimated 450 gpd (see figure A-1)
 or measured _____ x 1.5 (safety factor) = _____ gpd.

A-1: Estimated Sewage Flows in Gallons per Day

number of bedrooms	Class I	Class II	Class III	Class IV
2	300	225	180	60%
<u>3</u>	<u>450</u>	300	218	of the
4	600	375	256	values
5	750	450	294	in the
6	900	525	332	Class I,
7	1050	600	370	II, or III
8	1200	675	408	columns.

B. SEPTIC TANK Capacity

1,000 gallons (see figure C-1)

C-1: Septic Tank Capacities (in gallons)

Number of Bedrooms	Minimum liquid Capacity	Liquid capacity with garbage disposal	Liquid capacity with disposal lift inside
2 or less	750	1125	1500
<u>3 or 4</u>	<u>1000</u>	1500	2000
5 or 6	1500	2250	3000
7, 8 or 9	2000	3000	4000

C. SOILS (refer to site evaluation)

1. Depth to restricting layer = 1.5 feet
2. Depth of percolation tests = _____ feet
3. Texture Sandy loam
 Percolation rate _____ mpi
4. Soil loading rate .79 gpd/sqft (see figure D-33)
5. Percent land slope < 1 %

D. ROCK LAYER DIMENSIONS

1. Multiply average design flow (A) by 0.83 to obtain required rock layer area.
450 gpd x 0.83 sqft/gpd = 373.5 sqft
2. Determine rock layer width = 0.83 sqft/gpd x linear Loading Rate (LLR)
 0.83 sqft/gpd x .83 gpd/sqft = 0.69 ft
3. Length of rock layer = area ÷ width =
374 sqft (D1) ÷ 10 ft (D2) = 37.4 ft

MOUND LLR	
< 120 MPI	≤ 12
≥ 120 MPI	≤ 6

E. ROCK VOLUME

1. Multiply rock area (D1) by rock depth of 1 ft to get cubic feet of rock
375 sqft x 1 ft = 375 cuft
2. Divide cuft by 27 cuft/cuyd to get cubic yards.
375 cuft ÷ 27 cuyd/cuft = 13.88 cuyd
3. Multiply cubic yards by 1.4 to get weight of rock in tons
13.88 cuyd x 1.4 ton/cuyd = 19.44 tons

F. SEWAGE ABSORPTION WIDTH

Absorption width equals absorption ratio (See Figure D-33) times rock layer width (D2)

10 x 1.5 ft = 15 ft

D-33: Absorption Width Sizing Table

Percolation Rate in Minutes per Inch (MPI)	Soil Texture	Loading Rate Gallons per day per square foot	Absorption Ratio
Faster than 5	Coarse Sand, Pebbles, Gravel, Sand, Loam, Sand, Silty Sand	1.20	1.00
6 to 15	Sandy Loam	0.75	1.30
16 to 30	Loam	0.60	2.00
31 to 45	Silt Loam, Silty Sand	0.50	2.40
46 to 60	Sandy Clay Loam, Silty Clay Loam, Clay Loam	0.45	2.67
61 to 120	Silty Clay, Sandy Clay, Clay	0.34	3.00
Slower than 120*			

*System designed for these soils should be checked for performance

G. Mound Slope Width and Length
(landslope less than or equal to 1%)

1. Absorption width (F) 15 ft
2. Calculate mound size

a. Determine depth of clean sand fill at upslope edge of rock layer = 3 ft minus the distance to restricting layer (C1)

$3 \text{ ft} - 1.5 \text{ ft} = 1.5 \text{ ft}$

b. Mound height at the upslope edge of rock layer = depth of clean sand for separation (G2a) at upslope edge plus depth of rock layer (1 ft) plus depth of cover (1 ft)

$1.5 \text{ ft} + 1 \text{ ft} + 1 \text{ ft} = 3.5 \text{ ft}$

c. Berm width = upslope mound height (G2b) times 4 (4 is recommended, but could be 3-12)

$3.5 \times 4 = 14 \text{ ft}$

d. The total landscape width is the sum of berm (G2c) width plus rock layer width (D2) plus berm width (G2c):

$14 \text{ ft} + 10 \text{ ft} + 14 \text{ ft} = 38 \text{ ft}$

e. Additional width necessary for absorption = absorption width (F) minus the landscape width (G2d)

$15 \text{ ft} - 38 \text{ ft} = -23 \text{ ft}$, if number is negative (<0) skip to g

f. Final berm width = additional width (G2e) plus the berm width (G2c)

$\text{ft} + \text{ft} = \text{ft}$

g. Total mound width is the sum of berm width (G2f or G2c) plus rock layer width (D2) plus berm width (G2f or G2c):

$14 \text{ ft} + 10 \text{ ft} + 14 \text{ ft} = 38 \text{ ft}$

h. Total mound length is the sum of berm (G2f or G2c) plus rock layer length (D3) plus berm (G2f or G2c):

$14 \text{ ft} + 37.5 \text{ ft} + 14 \text{ ft} = 65.5 \text{ ft}$

i. Setbacks from the rockbed are calculated as follows: the absorption width (F) minus the rock bed width (D2) divided by 2:

$(15 \text{ ft} - 10 \text{ ft}) \div 2 = 2.5 \text{ ft}$

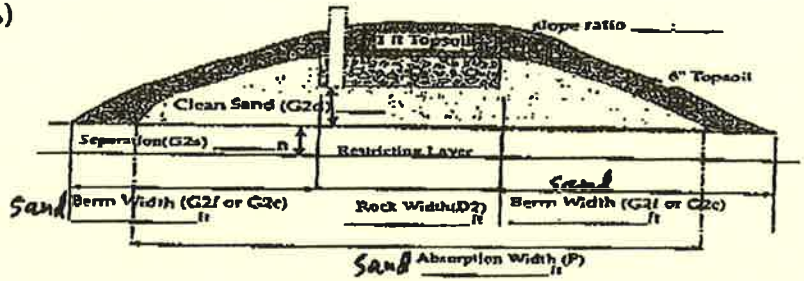

Final Dimensions:
65.5 x 38

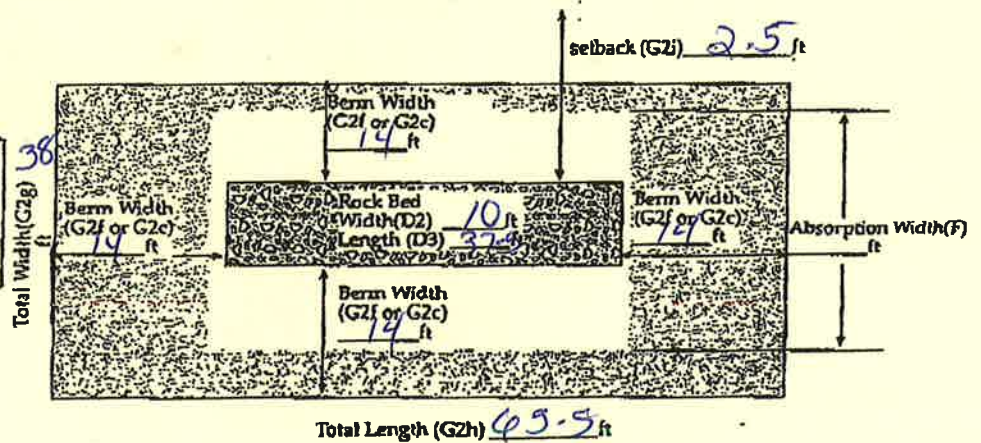

I hereby certify that I have completed this work in accordance with applicable ordinances, rules and laws.
Greg Westerlund (signature) 463 (license #) 5/18/16 (date)

MOUND CROSS-SECTION

<1

PERCENT SLOPE OF ORIGINAL SOIL

10 FT. x 37.5 FT. SIZE OF ROCKBED 38 FT. x 65.5 FT. SIZE OF SANDBASE

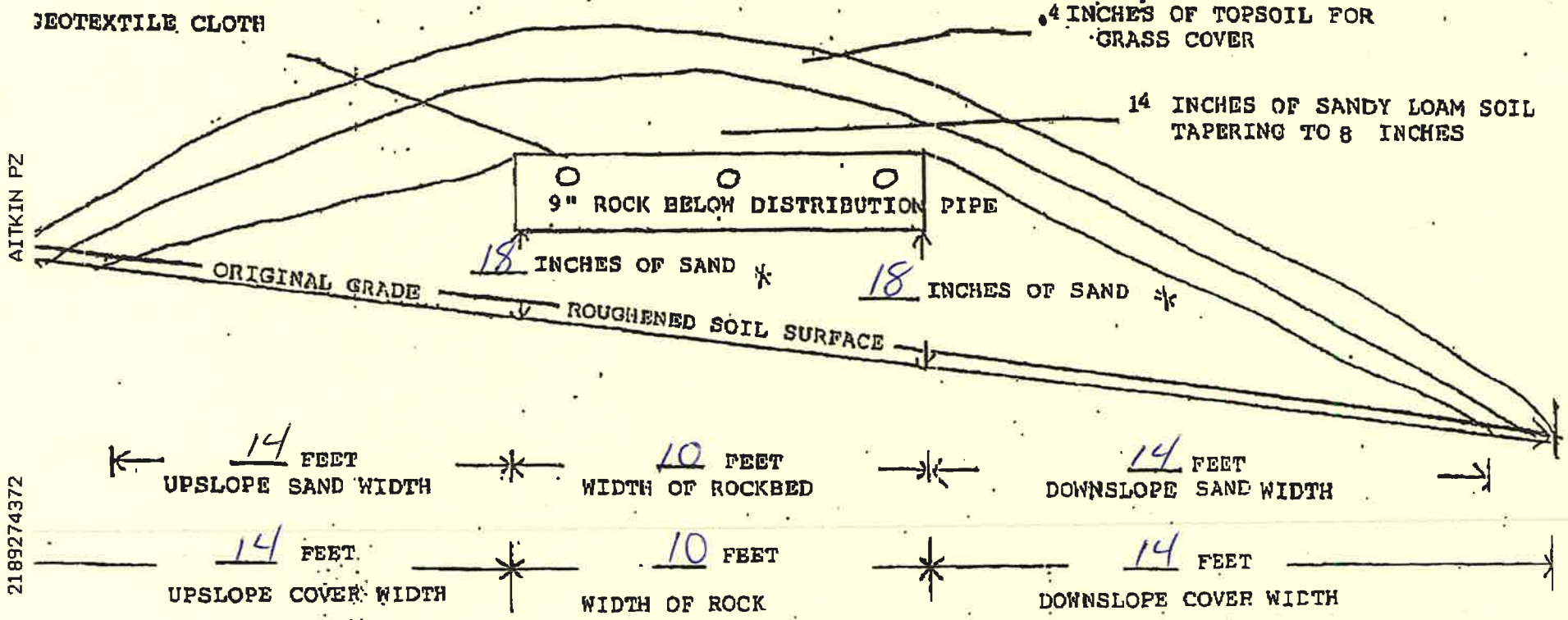

PRESSURE DISTRIBUTION SYSTEM

Geotextile fabric

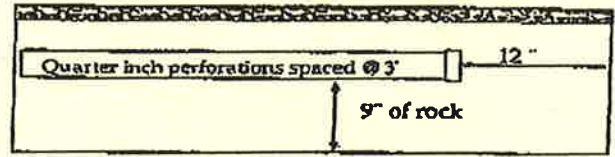

Perf Sizing 3/16" - 1/4"
Perf Spacing 1.5' - 5'

E-4: Maximum allowable number of 1/4-inch perforations per lateral to guarantee <10% discharge variation

perforation spacing (feet)	1 inch	1.25 inch	1.5 inch	2.0 inch
2.5	8	14	18	28
3.0	8	13	17	26
3.3	7	12	16	25
4.0	7	11	15	23
5.0	6	10	14	22

E-6: Perforation Discharge in gpm

head (feet)	perforation diameter (inches)			
	1/8	3/16	7/32	1/4
1.0 ^a	0.18	0.42	0.56	0.74
2.0 ^b	0.26	0.59	0.80	1.04
5.0	0.41	0.94	1.26	1.65

^a Use 1.0 foot for single-family homes.
^b Use 2.0 feet for anything else.

MANIFOLD LOCATED AT END OF PRESSURE DISTRIBUTION SYSTEM

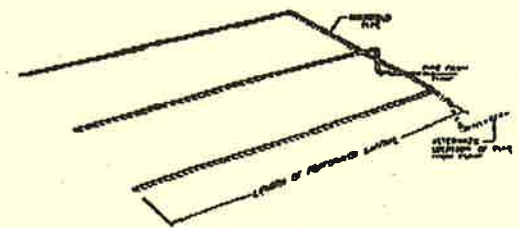

Layout of Perforated Pipe Laterals for Pressure Distribution at Manifold

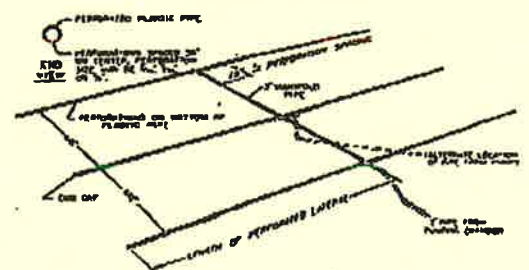

- Select number of perforated laterals 3
- Select perforation spacing = 2.5 ft
- Since perforations should not be placed closer than 1 foot to the edge of the rock layer (see diagram), subtract 2 feet from the rock layer length.

$$\frac{37.5}{\text{Rock layer length}} - 2 \text{ ft} = 35.5 \text{ ft}$$

- Determine the number of spaces between perforations. Divide the length (3) by perforation spacing (2) and round down to nearest whole number.

$$\text{Perforation spacing} = \frac{35.5 \text{ ft}}{2.5 \text{ ft}} = 14 \text{ spaces}$$

- Number of perforations is equal to one plus the number of perforation spaces(4). Check figure E-4 to assure the number of perforations per lateral guarantees <10% discharge variation.

$$14 \text{ spaces} + 1 = 15 \text{ perforations/lateral}$$

- A. Total number of perforations = perforations per lateral (5) times number of laterals (1)

$$15 \text{ perfs/lat} \times 3 \text{ lat} = 45 \text{ perforations}$$

- B. Calculate the square footage per perforation. Should be 6-10 sqft/perf. Does not apply to at-grades.

Rock bed area = rock width (ft) x rock length (ft)

$$10 \text{ ft} \times 37.5 \text{ ft} = 375 \text{ sqft}$$

Square foot per perforation = Rock bed area ÷ number of perfs (6)

$$\frac{375 \text{ sqft}}{45 \text{ perfs}} = 8.33 \text{ sqft/perf}$$

- Determine required flow rate by multiplying the total number of perforations (6A) by flow per perforation (see figure E-6)

$$45 \text{ perfs} \times 74 \text{ gpm/perfs} = 333 \text{ gpm}$$

- If laterals are connected to header pipe as shown on upper example, to select minimum required lateral diameter; enter figure E-4 with perforation spacing (2) and number of perforations per lateral (5) Select minimum diameter for perforated lateral = 1 1/2 inches.

- If perforated lateral system is attached to manifold pipe near the center, lower diagram, perforated lateral length (3) and number of perforations per lateral (5) will be approximately one half of that in step 8. Using these values, select minimum diameter for perforated lateral = _____ inches.

I hereby certify that I have completed this work in accordance with applicable ordinances, rules and laws.

Greg Westerlund (signature)

663 (license #)

5/18/16 (date)

PUMP SELECTION PROCEDURE

1. Determine pump capacity:

A. Gravity distribution

1. Minimum required discharge is 10 gpm
2. Maximum suggested discharge is 45 gpm. For other establishments at least 10% greater than the water supply rate, but no faster than the rate at which effluent will flow out of the distribution device.

B. Pressure distribution

See pressure distribution work sheet.

From A or B Selected pump capacity: 33.3 gpm

2. Determine pump head requirements:

A. Elevation difference between pump and point of discharge?

9 feet

B. Special head requirement? (See Figure at right - Special Head Requirements)

5 feet

C. Calculate Friction loss

1. Select pipe diameter 2 in

2. Enter Figure E-9 with gpm (1A or B) and pipe diameter (C1).

Read friction loss in feet per 100 feet from Figure E-9

Friction Loss = 2.06 ft/100ft of pipe

3. Determine total pipe length from pump discharge to soil treatment discharge point. Estimate by adding 25 percent to pipe length for fitting loss. Total pipe length times 1.25 = equivalent pipe length

45 feet x 1.25 = 56.25 feet

4. Calculate total friction loss by multiplying friction loss (C2) in ft/100 ft by the equivalent pipe length (C3) and divide by 100.

= 2.06 ft/100ft x 56.25 ÷ 100 = 1.16 ft

D. Total head required is the sum of elevation difference (A), special head requirements (B), and total friction loss (C4)

9 ft + 5 ft + 1.16 ft =

Total head: 15.16 feet

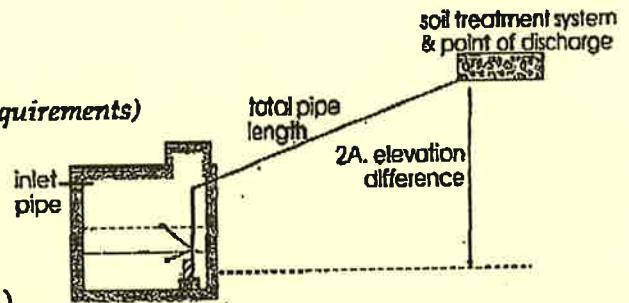

Special Head Requirements	
Gravity Distribution	0 ft
Pressure Distribution	5 ft

E-9: Friction Loss in Plastic Pipe Per 100 feet			
flow rate gpm	nominal pipe diameter		
	1.5"	2"	3"
20	2.47	0.73	0.11
25	3.73	1.11	0.16
30	5.23	1.55	0.23
<u>35</u>	6.96	<u>2.06</u>	0.30
40	8.91	2.64	0.39
45	11.07	3.28	0.48
50	13.46	3.99	0.58
55		4.76	0.70
60		5.60	0.82
65		6.48	0.95
70		7.44	1.09

3. Pump selection

A pump must be selected to deliver at least 33 gpm (1A or B) with at least 15 feet of total head (2D)

I hereby certify that I have completed this work in accordance with applicable ordinances, rules and laws.

Doug Westerlund (signature)

663 (license #)

5/18/16 (date)

1. Determine area

A. Rectangle area = L x W

$4.5 \times 5.58 = 25.11$ square feet

B. Circle area = π (3.14) x radius in feet x radius in feet

$3.14 \times \text{ft} \times \text{ft} = \text{sqft}$

C. Get area from manufacturer _____ sqft

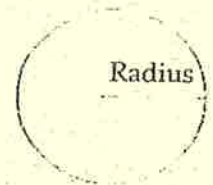
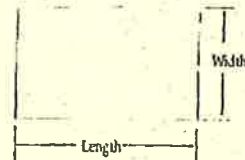

2. Calculate gallons per inch

There are 7.5 gallons per cubic foot of volume, therefore multiply the area (1A, B or C) times the conversion factor and divide by 12 inches per foot to calculate gallon per inch.

Area x 7.5 ÷ 12 = 25.11 sqft x 7.5 ÷ 12 in/ft = 15.69 gallon per inch

3. Calculate total tank volume

A. Depth from bottom of inlet pipe to tank bottom _____ in

B. Total tank volume = depth from bottom of inlet pipe to tank bottom (3A) x gal/in (2)

= 32 in x 15.69 gal/in = 815.88 gal

Legal Tank:

500 gallons or

100% the Daily flow

or

Alternating Pumps

4. Calculate gallons to cover pump (with 2-3 inches of water covering pump)

(Pump and block height (inch) + 2 inch) x gallon/inch

(16 in + 2 in) x 15.69 gal/in = 251 gallon

5. Calculate total pumpout volume

A. Select pump size for 4-5 does per day. Gallon per dose = gpd (see figure A-1) / doses per day = 450 gpd ÷ 4 doses/day = 112.5 gallons

B. Calculate drainback

1. Determine total pipe length, 45 feet

2. Determine liquid volume of pipe, 17 gal per ft (see figure E-20)

3. Drainback quantity = 45 ft (5B1) x 17 gal per ft (5B2) = 7.65 gal

C. Total pump out volume = dose volume (5A) + drainback (5B3)

112.5 gal + 7.65 gal = 120.15 Total gallon

A-1: Estimated Sewage Flows in Gallons per Day

number of bedrooms	Class I	Class II	Class III	Class IV
2	300	225	180	60%
3	450	300	218	of the
4	600	375	256	values
5	750	450	294	in the
6	900	525	332	Class I
7	1050	600	370	II, or III
8	1200	675	408	columns.

E-20: Volume of Liquid in Pipe

Pipe Diameter inches	Gallons per foot
1	0.045
1.25	0.078
1.5	0.11
<u>2</u>	<u>0.17</u>
2.5	0.25
3	0.38
4	0.66

6. Float separation distance (using total pumpout volume)

Total pumpout volume (5C) ÷ gal/inch (2)

120.15 gal ÷ 15.69 gal/in = 7.66 inch

7. Calculate volume for alarm (typically 2 to 3 inches)

Alarm depth (inch) x gallon/inch (2) = 2 in x 15.69 gal/in = 31.38 gal

8. Calculate total gallon = gallons over pump (4) + gallons pumpout (5C) + gallons alarm (7)

251 gal + 120.15 gal + 31.38 gal = 402.53 gallons

9. Total Tank Depth = total gallon (8) ÷ gallon/inch (2)

402.53 gal ÷ 15.69 gal/in = 25.66 in

Recommended:

Calculate reserve capacity (75% the daily flow)

Daily flow x .75 = 450 x .75 = 337.5 gallons

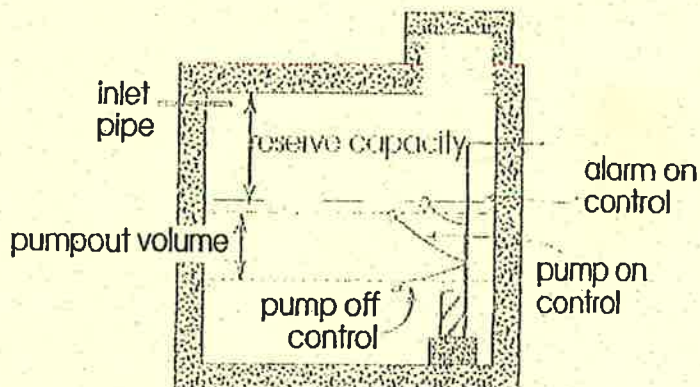

I hereby certify that I have completed this work in accordance with applicable ordinances, rules and laws.

Dreg Westerlund (signature)

663 (license #)

5/18/16 (date)

CLIENT: Harvey Boyd

MAP DRAWN TO SCALE WITH A NORTH ARROW

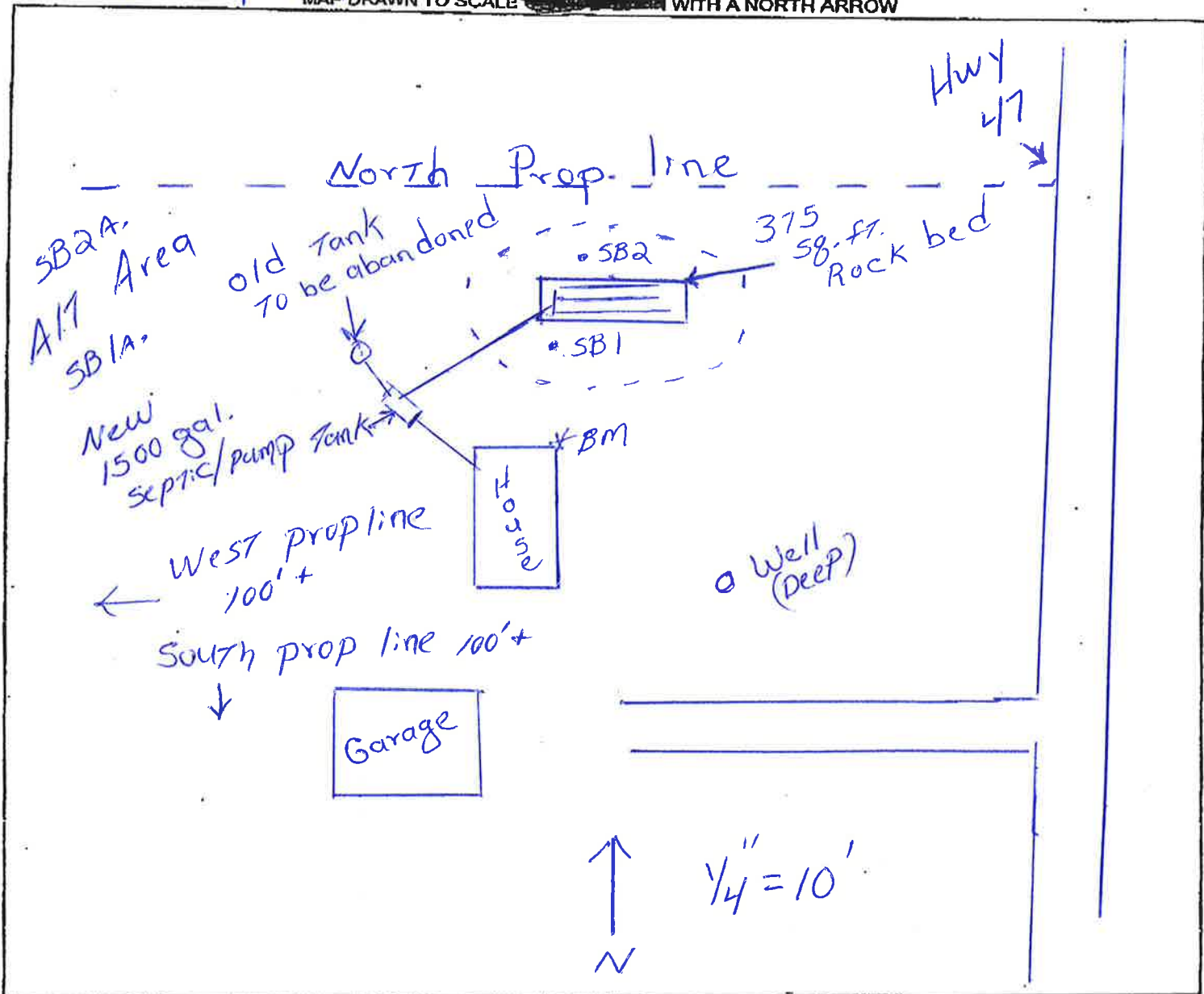

CHECK OFF LIST-HAVE ALL OF THE FOLLOWING BEEN DRAWN ON THE MAP??

SHOW EXISTING OR PROPOSED

- WATER WELLS WITHIN 100 FT OF TREATMENT AREAS
- PRESSURE WATER LINES WITHIN 10 FT OF TREATMENT AREAS
- STRUCTURES
- ALL SOIL TREATMENT AREAS
- HORIZONTAL AND VERTICAL REFERENCE
- POINT OF SOIL BORINGS
- LOT EASEMENTS
- DISTURBED/ COMPACTED AREAS
- SITE PROTECTION-LATHE AND RIBBON EVERY 15 FT
- ACCESS ROUTE FOR TANK MAINTENANCE
- LOT IMPROVEMENTS
- ALL ISTS COMPONENTS
- DIRECTION OF SLOPE
- ALL LOT DIMENSIONS

REQUIRED SETBACKS

- STRUCTURES
- OHW
- PROPERTY LINES

COMMENTS:

INDICATE ELEVATIONS

- BENCHMARK 100
- ELEVATION OF SEWER LINE @ HOUSE 97
- ELEVATION @ TANK INLET 96.5
- ELEVATION @ BOTTOM OF ROCK LAYER 100.5
- ELEVATION @ BOTTOM OF BORING OR RESTRICTIVE LAYER 97
- ELEVATION OF PUMP 92.5
- ELEVATION OF DISTRIBUTION DEVICE 101.5

DESIGNER SIGNATURE Greg Westerlund

LICENSE# 663

DATE 5/18/16



Septic System Management Plan for Mound Systems

The goal of a septic system is to protect human health and the environment by properly treating wastewater before returning it to the environment. Your septic system is designed to kill harmful organisms and remove pollutants before the water is recycled back into our lakes, streams and groundwater.

This **management plan** will identify the operation and maintenance activities necessary to ensure long-term performance of your septic system. Some of these activities must be performed by you, the homeowner. Other tasks must be performed by a licensed septic maintainer or service provider. However, it is YOUR responsibility to make sure all tasks get accomplished in a timely manner.

The University of Minnesota's *Septic System Owner's Guide* contains additional tips and recommendations designed to extend the effective life of your system and save you money over time.

Proper septic system design, installation, operation and maintenance means safe and clean water!

Property Owner	<u>Harvey Boyd</u>	
Property Address	<u>23229 Hwy 47</u>	Property ID <u>21-0-048500</u>
System Designer	<u>Greg Westerlund</u>	License # <u>663</u>
System Installer	<u>Westerlund</u>	License # <u>663</u>
Service Provider/Maintainer		Phone _____
Permitting Authority		Phone _____
Permit #		Date Inspected _____

Keep this Management Plan with your *Septic System Owner's Guide*. The *Septic System Owner's Guide* includes a folder designed to hold maintenance records including pumping, inspection and evaluation reports. Ask your septic professional to also:

- Attach permit information, designer drawings and as-builts of your system, if they are available.
- Keep copies of all pumping records and other maintenance and repair invoices with this document.
- Review this document with your maintenance professional at each visit; discuss any changes in product use or water-use appliances.

For a copy of the *Septic System Owner's Guide*, call 1-800-876-8636 or go to <http://shop.extension.umn.edu/>

<http://septic.umn.edu>



Information on Your System

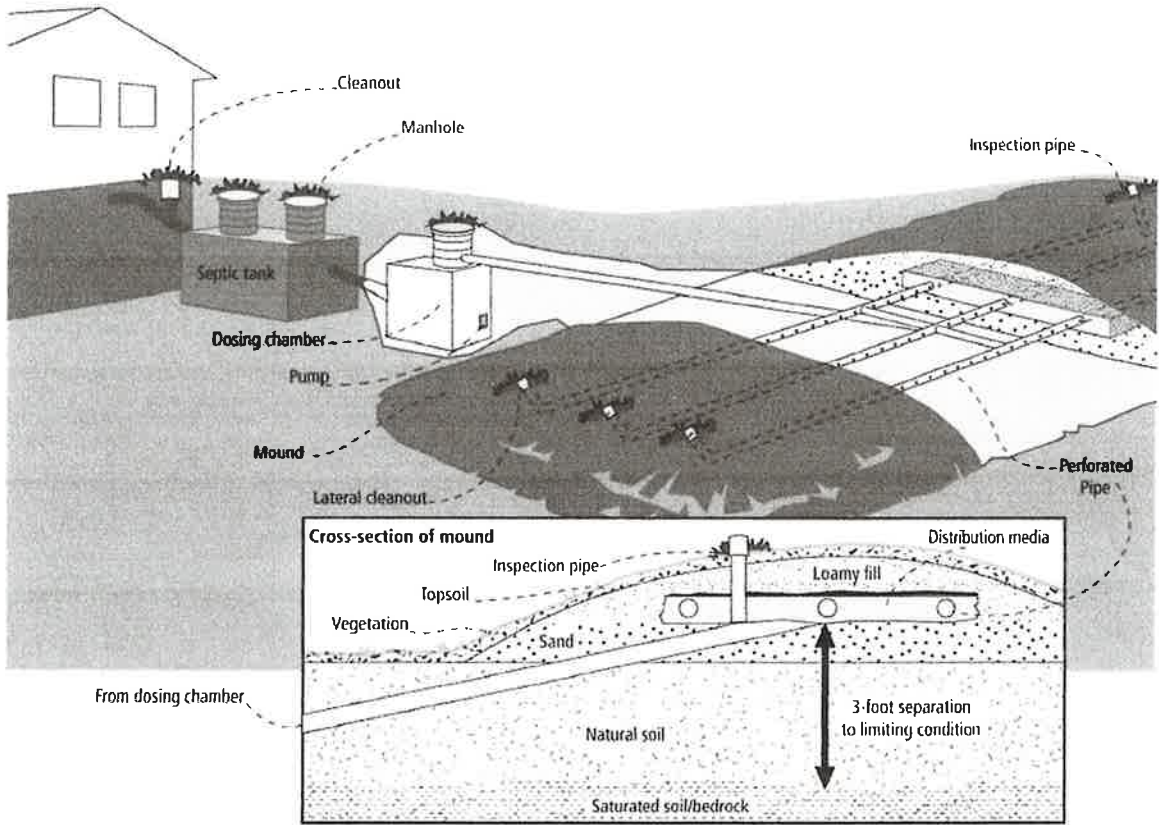

Dwelling Type	Well Construction
Number of bedrooms: <u>3</u>	Well depth (ft): _____
System capacity/ design flow (gpd): <u>450</u>	<input type="checkbox"/> Cased well Casing depth: _____
Anticipated average daily flow (gpd): <u>< 400</u>	<input type="checkbox"/> Other (specify): _____
Comments _____	Distance from septic (ft): <u>80'+</u>
In-home business? <u>N</u> What type? _____	Is the well on the design drawing? <u>(Y)</u> N

Septic Tank	
<input type="checkbox"/> One tank Tank volume: <u>1,000</u> gallons	<input type="checkbox"/> Pump Tank (if one) <u>500</u> gallons
Does tank have two compartments? Y <u>(N)</u>	<input type="checkbox"/> Effluent Pump type: <u>Zoeller</u>
<input type="checkbox"/> Two tanks Tank volume: _____ gallons	TDH <u>15</u> Feet of head
<input type="checkbox"/> Tank is constructed of <u>PreCast Con.</u>	Pump capacity <u>33</u> GPM
<input type="checkbox"/> Effluent Screen type: <u>NO</u>	<input type="checkbox"/> Alarm <input checked="" type="checkbox"/> visual <input checked="" type="checkbox"/> audible

Soil Treatment Area	
Mound area (length x width): <u>66</u> ft x <u>38</u> ft	<input type="checkbox"/> Cleanouts or Inspection Ports
Rock bed size (length x width): <u>10</u> ft x <u>38</u> ft	<input type="checkbox"/> Surface Water Diversions



Maintenance Log

Track maintenance activities here for easy reference. See list of management tasks on page 2.

Activity	Date accomplished									
<i>Check frequently:</i>										
Leaks: check for plumbing leaks										
Soil treatment area check for surfacing										
Lint filter: check, clean if needed										
Effluent screen: if owner-maintained										
<i>Check annually:</i>										
Water usage rate (monitor frequency____)										
Caps: inspect, replace if needed										
Water use appliances – review use										
Other:										

Notes:

"I understand it is my responsibility to properly operate and maintain the sewage treatment system on this property, utilizing the Management Plan. If requirements in this Management Plan are not met, I will promptly notify the permitting authority and take necessary corrective actions. If I have a new system, I agree to adequately protect the reserve area for future use as a soil treatment system."

Property Owner Signature: _____ Date _____
 Designer Signature: *Greg Westerlund* Date *5/18/16*
 Permitting Authority Signature: _____ Date _____

©2006 Regents of the University of Minnesota. All rights reserved. The University of Minnesota is an equal opportunity educator and employer. This material is available in alternative formats upon request. Contact the Water Resources Center, 612-624-9282. The Onsite Sewage Treatment Program is delivered by the University of Minnesota Extension Service and the University of Minnesota Water Resources Center.



Homeowner Management Tasks

These operation and maintenance activities are your responsibility. Use the chart on page 6 to track your activities.

Identify the service intervals recommended by your system designer and your local government. The tank assessment for your system will be the shortest interval of these three intervals. Your pumper/maintainer will determine if your tank needs to be pumped.

System Designer: check every 36 months
Local Government: check every _____ months
State Requirement: check every 36 months

My tank needs to be checked
every _____ months

Seasonally or several times per year

- Leaks.* Check (listen, look) for leaks in toilets and dripping faucets. Repair leaks promptly.
- Surfacing sewage.* Regularly check for wet or spongy soil around your soil treatment area. If surfaced sewage or strong odors are not corrected by pumping the tank or fixing broken caps, call your service professional. *Untreated sewage may make humans and animals sick.*
- Alarms.* Alarms signal when there is a problem; contact your maintainer any time the alarm signals.
- Lint filter.* If you have a lint filter, check for lint buildup and clean when necessary.
- Effluent screen.* If you have an effluent screen, inspect and clean it twice a year or per manufacturer recommendations.

Annually

- Water usage rate.* A water meter can be used to monitor your average daily water use. Compare your water usage rate to the design flow of your system (listed on the next page). Contact your septic professional if your average daily flow over the course of a month exceeds 70% of the design flow for your system.
- Caps.* Make sure that all caps and lids are intact and in place. Inspect for damaged caps at least every fall. Fix or replace damaged caps before winter to help prevent freezing issues.
- Water conditioning devices.* See Page 5 for a list of devices. When possible, program the recharge frequency based on *water demand (gallons)* rather than *time (days)*. Recharging too frequently may negatively impact your septic system.
- Review your water usage rate.* Review the Water Use Appliance chart on Page 5. Discuss any major changes with your pumper/maintainer.

During each visit by a pumper/maintainer

- Ask if your pumper/maintainer is licensed in Minnesota.
- Make sure that your pumper/maintainer services the tank through the manhole. (NOT through a 4" or 6" diameter inspection port.)
- Ask your pumper/maintainer to accomplish the tasks listed on the Professional Tasks on Page 3.



Professional Management Tasks

These are the operation and maintenance activities that a pumper/maintainer performs to help ensure long-term performance of your system. Professionals should refer to the O/M Manual for detailed checklists for tanks, pumps, alarms and other components. Call 800-322-8642 for more details.

- Written record provided to homeowner after each visit.

Plumbing/Source of Wastewater

- Review the Water Use Appliance Chart on Page 5 with homeowner. Discuss any changes in water use and the impact those changes may have on the septic system.
- Review water usage rates (if available) with homeowner.

Septic Tank/Pump Tanks

- Manhole lid.* A riser is recommended if the lid is not accessible from the ground surface. Insulate the riser cover for frost protection.
- Liquid level.* Check to make sure the tank is not leaking. The liquid level should be level with the bottom of the outlet pipe. (If the water level is below the bottom of the outlet pipe, the tank may not be watertight. If the water level is higher than the bottom of the outlet pipe of the tank, the effluent screen may need cleaning, or there may be ponding in the drainfield.)
- Inspection pipes.* Replace damaged caps.
- Baffles.* Check to make sure they are in place and attached, and that inlet/outlet baffles are clear of buildup or obstructions.
- Effluent screen.* Check to make sure it is in place; clean per manufacturer recommendation.
- Alarm.* Verify that the alarm works.
- Scum and sludge.* Measure scum and sludge in each tank, pump if needed.

Pump

- Pump and controls.* Check to make sure the pump and controls are operating correctly.
- Pump vault.* Check to make sure it is in place; clean per manufacturer recommendations.
- Alarm.* Verify that the alarm works.
- Drainback.* Check to make sure it is operating properly.
- Event counter or run time.* Check to see if there is an event counter or run time log for the pump. If there is one, calculate the water usage rate and compare to the anticipated average daily flow listed on Page 4.

Soil Treatment Area

- Inspection pipes.* Check to make sure they are properly capped. Replace caps that are damaged.
- Surfacing of effluent.* Check for surfaced effluent or other signs of problems.
- Lateral flushing.* Check lateral distribution; if cleanouts exist, flush and clean as needed.
- Ponding.* Check for ponding. Excessive ponding in mounds indicates a problem.

All other components – inspect as listed here:

**Water-Use Appliances and
Equipment in the Home**

Appliance	Impacts on System	Management Tips
Garbage disposal	<ul style="list-style-type: none"> • Uses additional water. • Adds solids to the tank. • Finely-ground solids may not settle. Unsettled solids can exit the tank and enter the soil treatment area. 	<ul style="list-style-type: none"> • Use of a garbage disposal is not recommended. • Minimize garbage disposal use. Compost instead. • To prevent solids from exiting the tank, have your tank pumped more frequently. • Add an effluent screen to your tank.
Washing machine	<ul style="list-style-type: none"> • Washing several loads on one day uses a lot of water and may overload your system. • Overloading your system may prevent solids from settling out in the tank. Unsettled solids can exit the tank and enter the soil treatment area. 	<ul style="list-style-type: none"> • Choose a front-loader or water-saving top-loader, these units use less water than older models. • Limit the addition of extra solids to your tank by using a liquid or easily biodegradable detergents. • Install a lint filter after the washer and an effluent screen on your tank. • Wash only full loads. • Limit use of bleach-based detergents. • Think even – spread your laundry loads throughout the week.
2 nd floor laundry	<ul style="list-style-type: none"> • The rapid speed of water entering the tank may reduce performance. 	<ul style="list-style-type: none"> • Install an effluent screen in the septic tank to prevent the release of excessive solids to the soil treatment area. • Be sure that you have adequate tank capacity.
Dishwasher	<ul style="list-style-type: none"> • Powdered and/or high-phosphorus detergents can negatively impact the performance of your tank and soil treatment area. • New models promote “no scraping”. They have a garbage disposal inside. 	<ul style="list-style-type: none"> • Use gel detergents. Powdered detergents may add solids to the tank. • Use detergents that are low or no-phosphorus. • Wash only full loads. • Scrape your dishes anyways to keep undigested solids out of your septic system.
Grinder pump (in home)	<ul style="list-style-type: none"> • Finely-ground solids may not settle. Unsettled solids can exit the tank and enter the soil treatment area. 	<ul style="list-style-type: none"> • Expand septic tank capacity by a factor of 1.5. • Include pump monitoring in your maintenance schedule to ensure that it is working properly. • Add an effluent screen.
Large bathtub (whirlpool)	<ul style="list-style-type: none"> • Large volume of water may overload your system. • Heavy use of bath oils and soaps can impact biological activity in your tank and soil treatment area. 	<ul style="list-style-type: none"> • Avoid using other water-use appliances at the same time. For example, don't wash clothes and take a bath at the same time. • Use oils, soaps, and cleaners in the bath or shower sparingly.
Clean Water Uses	Impacts on System	Management Tips
High-efficiency furnace	<ul style="list-style-type: none"> • Drip may result in frozen pipes during cold weather. 	<ul style="list-style-type: none"> • Re-route water into a sump pump or directly out of the house. Do not route furnace recharge to your septic system.
Water softener Iron filter Reverse osmosis	<ul style="list-style-type: none"> • Salt in recharge water may affect system performance. • Recharge water may hydraulically overload the system. 	<ul style="list-style-type: none"> • These sources produce water that is clean; clean water should not go into your septic system. • Reroute water from these sources to another outlet, such as a dry well or old drainfield. • When replacing consider using a demand-based recharge vs. a time-based recharge.
Surface drainage Footing drains	<ul style="list-style-type: none"> • Water from these sources will likely overload the system. 	<ul style="list-style-type: none"> • Check valves to ensure proper operation; have unit serviced per manufacturer directions